

ATTENZIONE - ATTENTION - ACHTUNG

- VERIFICARE LE MISURE DI INGOMBRO PER POSSIBILE INTERFERENZA SU ALCUNI MODELLI DI MACCHINE
- Please check the overall sizes for possible interferences on some machine models
- Bitte überprüfen sie das ausmass um mögliche interferenzen auf einigen maschinen modellen zu vermeiden

ATTENZIONE - ATTENTION - ACHTUNG

- Per lo smontaggio degli utensili utilizzare sempre la chiave di contrasto come indicato nel manuale d'uso.
- For disassembly of the tools use always the contrast key as mentioned in the user instructions.
- Fuer das Abmontieren der Werkzeuge immer den Gegenschlüssel benutzen wie in der Bedienungsanleitung erwaehtnt.

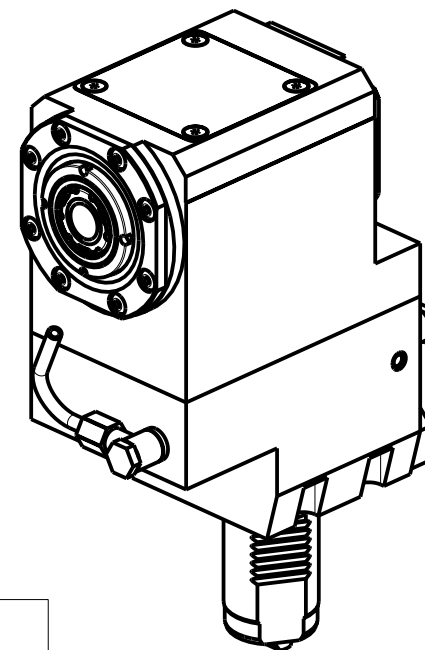

- Chiave inclusa
- Key included
- Schlüssel inbegriffen

Cod. MT	Mandrino Spindle Spindel	I	RPM	Coppia Max Max Torque Max Drehmoment	Lubr.esterna Ext. coolant Aussenkuehlung	CHIAVI NON INCLUSE Keys not included Schlüssel nicht einbegriffen		
MZK0470225	ERA25+ERA25	1:2	12000	50Nm	X	CHUB27	OKU0650004 *	CHTAER25ZC *

MAZAK
 SQT 15-18M/MS/MY/MSY 12 STAZIONI - SQT200-250M/MS/MY/MSY 12 STAZIONI - QT NEXUS 200-250M/MS/MY/MSY 12 STAZIONI
 QT NEXUS 20011-25011 M/MS/MY/MSY 12 STAZIONI - SUPER QUADREX 200-250M

MODULO MOTORIZZATO ASSIALE BISPORGENTE MOLTIPLICATO I=1:2
 Axial geared-up I=1:2 opposite face twin driven tool
 Axial angetriebenes Werkzeug halb vorspringend uebersetzt I=1:2

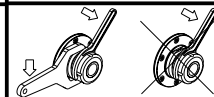

M.T. srl
 Via Casino Albini 480
 Tel. 0541/956034-957884
 Fax 0541/956341
 47842 S. GIOVANNI IN M. (RN)
 e-mail: mtma@mtmarchetti.com
 http://www.mtmarchetti.com



MZK250-1-10

Subject to change without notice.

03/2024