

ATTENZIONE - ATTENTION - ACHTUNG

- Per lo smontaggio degli utensili utilizzare sempre la chiave di contrasto come indicato nel manuale d'uso.
- For disassembly of the tools use always the contrast key as mentioned in the user instructions.
- Fuer das Abmontieren der Werkzeuge immer den Gegenschlüssel benutzen wie in der Bedienungsanleitung erwaeht.

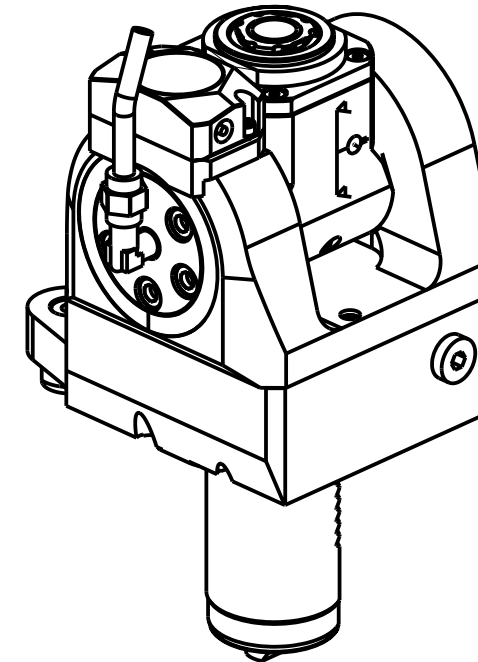
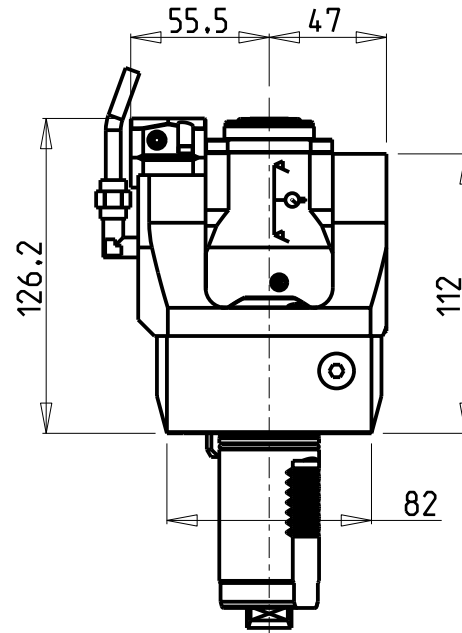
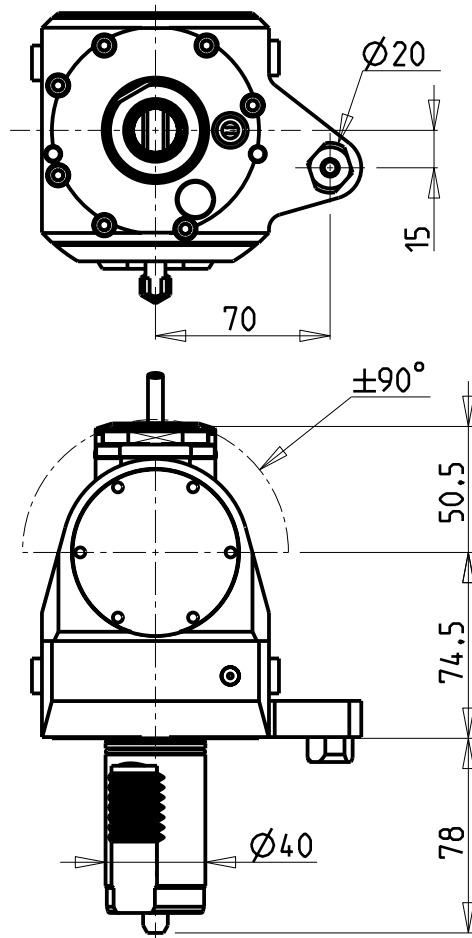

Cod. MT	Mandrino Spindle Spindel	I	RPM	Coppia Max Max Torque Max Drehmoment	Lubrificazione int. Coolant through Innenkuehlung	Lubrificazione est. Ext. coolant Aussenkuehlung	CHIAVI INCLUSE Keys included Schluessel inbegriffen		
MZK0255120	ER A 20	1:1	6000	30Nm	-	X	CHUB36	CHUB22	CHTAER20ZC
MZK0255220	ER A 20	1:1	6000	30Nm	P=70bar	X	CHUB36	CHUB22	CHTAER20ZC

MAZAK
 SQT 15-18M/MS/MY/MSY 12 STAZIONI - SQT200-250M/MS/MY/MSY 12 STAZIONI - QT NEXUS 200-250M/MS/MY/MSY 12 STAZIONI
 QT NEXUS 20011-25011 M/MS/MY/MSY 12 STAZIONI - SUPER QUADREX 200-250M - IVS200/300M

MODULO MOTORIZZATO ORIENTABILE ±90° CON NONIO DIGITALE
 ±90° adjustable angle driven tool with digital display
 Angetriebenes Werkzeug schwenkbar ±90° mit digital display

Subject to change without notice.

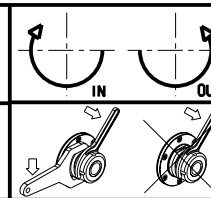

M.T. srl
 Via Casino Albini 480
 Tel. 0541/956034-957884
 Fax 0541/956341
 47842 S. GIOVANNI IN M. (RN)
 e-mail: mtma@mtmarchetti.com
 http://www.mtmarchetti.com

