

ATTENZIONE - ATTENTION - ACHTUNG

- Per lo smontaggio degli utensili utilizzare sempre la chiave di contrasto come indicato nel manuale d'uso.
- For disassembly of the tools use always the contrast key as mentioned in the user instructions.
- Fuer das Abmontieren der Werkzeuge immer den Gegenschlüssel benutzen wie in der Bedienungsanleitung erwaeht.

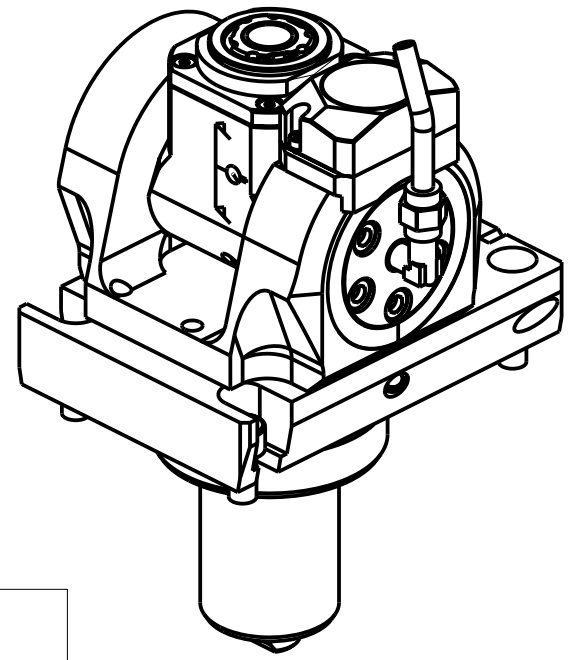

Cod. MT	Mandrino Spindle Spindel	I	RPM	Coppia Max Max Torque Max Drehmoment	Lubrificazione int. Coolant through Innenkuehlung	Lubrificazione est. Ext. coolant Aussenkuehlung	CHIAVI INCLUSE Keys included Schluessel inbegriffen			
MZK1085120	ERA20	1:1	6000	30Nm	-	X	CHUB36	CHUB22	CHTAER20ZC	CHESLO6
MZK1085220	ERA20	1:1	6000	30Nm	P=70bar	X	CHUB36	CHUB22	CHTAER20ZC	CHESLO6

MAZAK

MOD: QUICK TURN SMART 100M/150M/200M/250M - QT 100/200/250M 12ST.
QTC100/200/300M - QTE100/200/300M - QTU 200/250/350M - QT-Ez 8/10/12M

MODULO MOTORIZZATO ORIENTABILE ±90° CON NONIO DIGITALE

±90° adjustable angle driven tool with digital display

Angetriebenes Werkzeug schwenkbar ±90° mit digital display

Subject to change without notice.

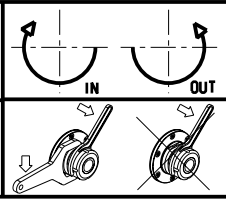

M.T. srl
Via Casino Albini 480
Tel. 0541/956034-957884
Fax 0541/956341
47842 S. GIOVANNI IN M. (RN)
e-mail: mtma@mtmarchetti.com
http://www.mtmarchetti.com



MZK335-7-01