

**DOTAZIONI - SUPPLIED WITH - AUSSTATTUNG**

mm / inch

- N°1 ALBERO + DISTANZIALI
- N°1 SHAFT + SPACER
- N°1 DORN + ABSTANDSSTUECK

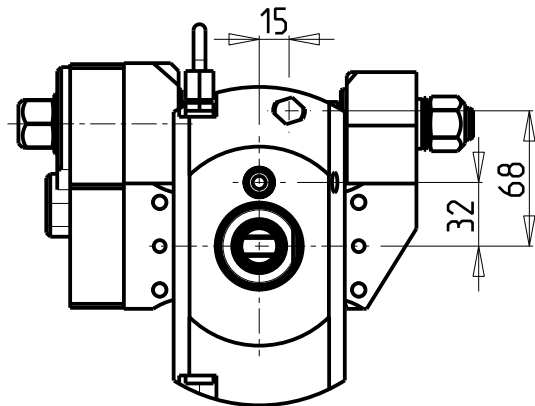

INCLINAZIONE  
REGOLABILE ±20°

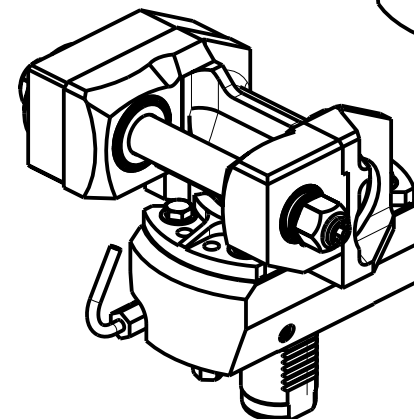
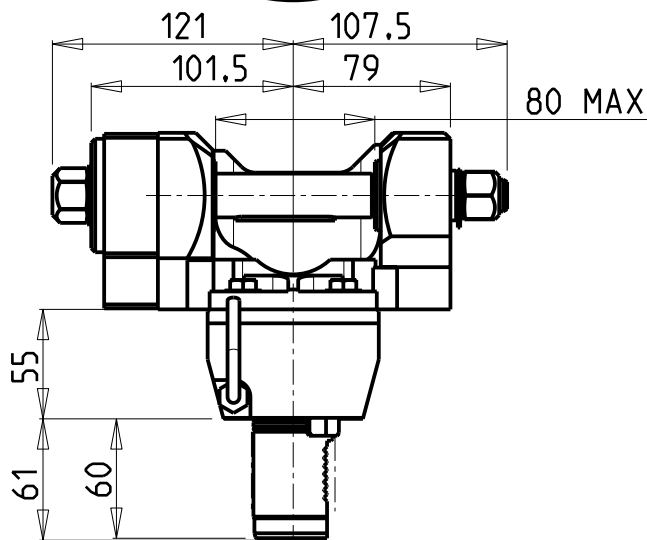
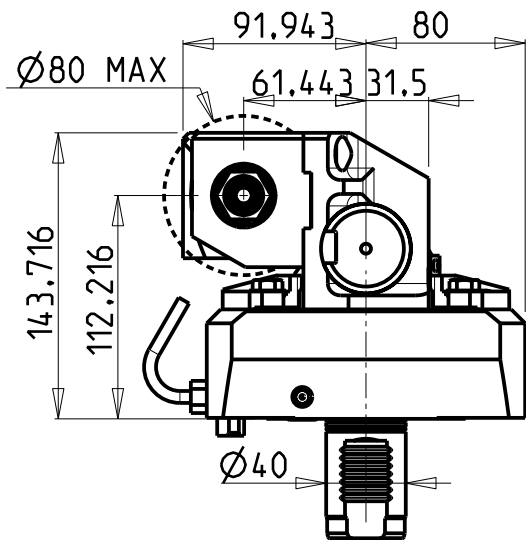
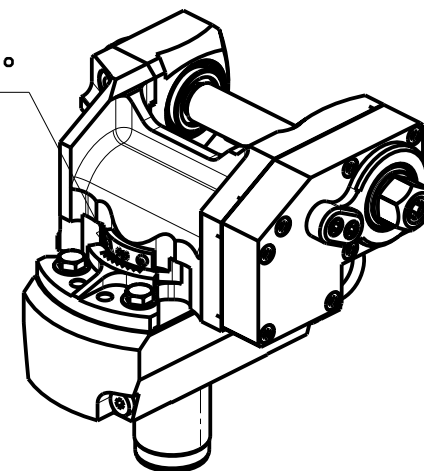

PER ALBERI E DISTANZIALI VEDI PAG. TBL250-1-00  
FOR SHAFT END SPACER SEE PAGE TBL250-1-00  
FUER DORN UND ABSTANDSSTUECK SEITE TBL250-1-00

-LA FUNZIONE DI POLIGONATURA/DENTATURA  
DEVE ESSERE INSTALLATA SULLA MACCHINA  
-POLYGON CUTTING/GEAR HOBBING FUNCTION  
MUST BE INSTALLED ON THE MACHINE  
-DIE FUNKTION FÜR POLYGON-BZW. VERZÄHNUNGSFRÄSEN  
MUSS AUF DER MASCHINE FREIGESCHALTET WERDEN

Cod. MT	i	RPM max	Coppia Max Max Torque Max Drehmoment	Lubrificazione est. Ext. coolant Aussenkuehlung	D (mm)	D (Inch)	CHIAVI INCLUSE Keys included Schlüssel inbegriffen		
							CHUB24	CHUB13	CHESL08
MZK0191100	1:1	6000	60Nm	X	16-22-27-32	3/4"-1"-1 1/4"	CHUB24	CHUB13	CHESL08
MZK0192100	2:1	3000	80Nm	X	16-22-27-32	3/4"-1"-1 1/4"	CHUB24	CHUB13	CHESL08

**MAZAK**

MOD: MULTIPLEX 610/6100 12 STAZIONI - MULTIPLEX 620/6200 16 STAZIONI  
HYPER QUADREX 100/150MSX/MSY 12 STAZIONI - HYPER QUADREX 200-250MS/MSY 16 STAZIONI

MODULO MOTORIZZATO PORTACREATORE

Driven gear hobber

Angetriebenes Zahnradwaeltzraes-Werkzeug

Subject to change without notice.

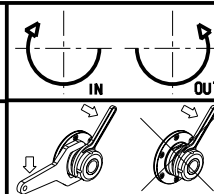

**M.T. srl**

Via Casino Albini 480  
Tel. 0541/956034-957884  
Fax 0541/956341

47842 S. GIOVANNI IN M. (RN)  
e-mail: mtma@mtmarchetti.com  
http://www.mtmarchetti.com



MZK340-4-00