

Ø16  
TOOL DIAMETER

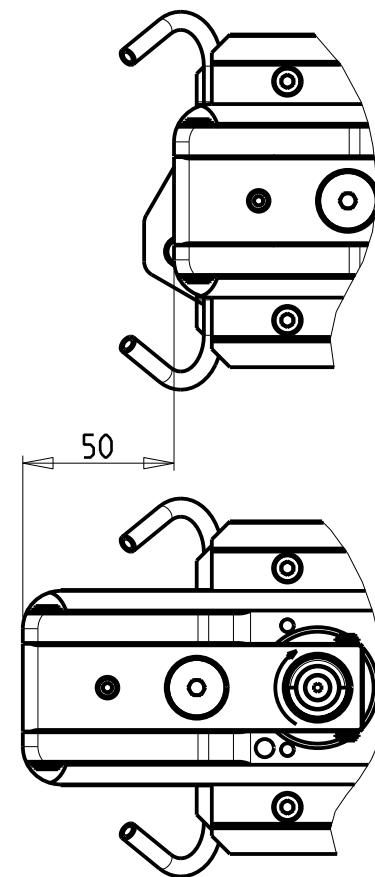
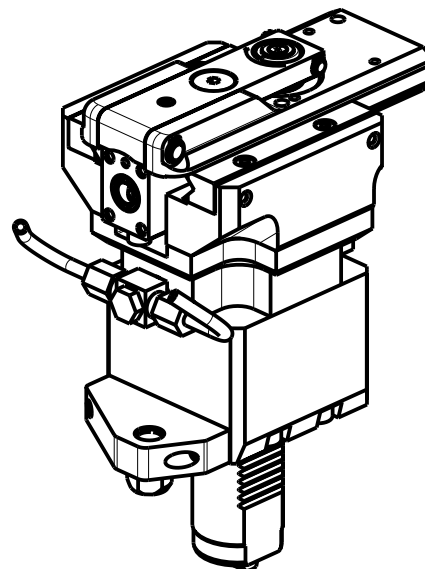

**DOTAZIONI - SUPPLIED WITH - AUSSTATTUNG**

N°1 Boccola di riduz. Ø16-Ø12 e N°1 Boccola di riduz. Ø16-Ø10  
 N°1 Reduction bush Ø16-Ø12 and N°1 Reduction bush Ø16-Ø10  
 N°1 Reduzierbuchsen Ø16-Ø12 und N°1 Reduzierbuchsen Ø16-Ø10

PER UTENSILI STOZZATORI VEDI PAG. TBL400-1-00  
 FOR DRIVEN SLOTTING TOOL CUTTING-TOOLS SEE PAGE TBL400-1-00  
 FÜR NUTENSTOSS-WERKZEUG SCHNEIDWERKZEUGE SIEHE SEITE TBL400-1-00

Cod. MT	I	RPM MAX	Lubr. esterna Ext. coolant Aussenkuehlung
MZK0400100	4:1	2000	X

**MAZAK**

MULTIPLEX 420-620-625-6200-6250 12 STAZIONI / HYPER QUADREX 200-250MSY 12 STAZIONI  
 MULTIPLEX 8200 (TORRETTA SUP. 12 STAZIONI)

MODULO MOTORIZZATO STOZZATORE CORSA 50mm H=130mm

Slotting driven tool 50mm stroke H=130mm

Keilnutenstossmaschine 50mm Hub H=130mm

Subject to change without notice.

**M.T. srl**

Via Casino Albini 480  
 Tel. 0541/956034-957884  
 Fax 0541/956341  
 47842 S. GIOVANNI IN M. (RN)  
 e-mail: mtma@mtmarchetti.com  
 http://www.mtmarchetti.com



**MZK360-3-00**