

ATTENZIONE - ATTENTION - ACHTUNG

- Per lo smontaggio degli utensili utilizzare sempre la chiave di contrasto come indicato nel manuale d'uso.
- For disassembly of the tools use always the contrast key as mentioned in the user instructions.
- Fuer das Abmontieren der Werkzeuge immer den Gegenschlüssel benutzen wie in der Bedienungsanleitung erwaeht.

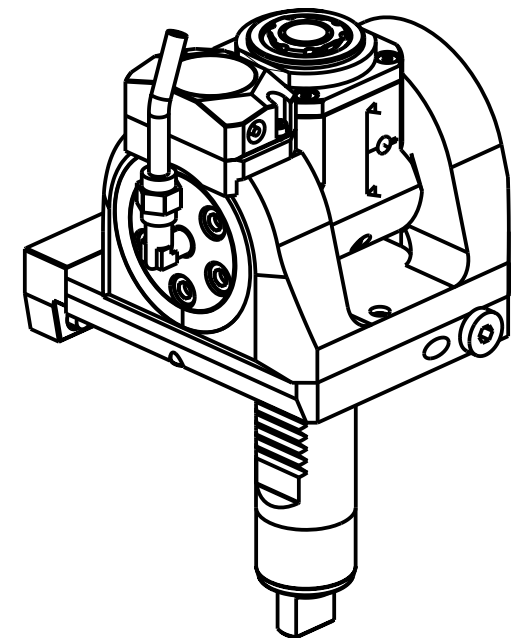

Cod. MT	Mandrino Spindle Spindel	I	RPM	Coppia Max Max Torque Max Drehmoment	Lubrificazione int. Coolant through Innenkuehlung	Lubrificazione est. Ext. coolant Aussenkuehlung	CHIAVI INCLUSE Keys included Schluessel inbegriffen		
MZT0055120	ER A 20	1:1	6000	30Nm	-	X	CHUB36	CHUB22	CHTAER20ZC
MZT0055220	ER A 20	1:1	6000	30Nm	P=70bar	X	CHUB36	CHUB22	CHTAER20ZC

DMG-MORI
MOD: ZT1000/1500 12 STAZIONI

MODULO MOTORIZZATO ORIENTABILE ±90° CON NONIO DIGITALE
±90° adjustable angle driven tool with digital display
Angetriebenes Werkzeug schwenkbar ±90° mit digital display

Subject to change without notice.

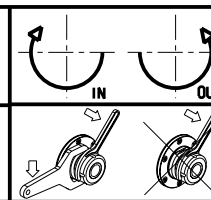

M.T. srl
Via Casino Albini 480
Tel. 0541/956034-957884
Fax 0541/956341
47842 S. GIOVANNI IN M. (RN)
e-mail: mtma@mtmarchetti.com
http://www.mtmarchetti.com



MZT335-1-01