

ATTENZIONE - ATTENTION - ACHTUNG

- Per lo smontaggio degli utensili utilizzare sempre la chiave di contrasto come indicato nel manuale d'uso.
- For disassembly of the tools use always the contrast key as mentioned in the user instructions.
- Fuer das Abmontieren der Werkzeuge immer den Gegenschlüssel benutzen wie in der Bedienungsanleitung erwäehnt.

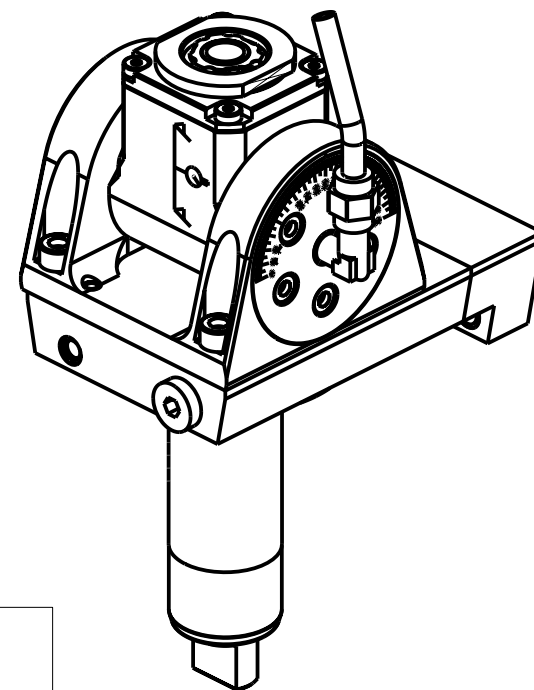

Cod. MT	Mandrino Spindle Spindel	I	RPM	Coppia Max Max Torque Max Drehmoment	Lubr.interna Coolant through Innenkuehlung	Lubrificazione est. Ext. coolant Aussenkuehlung	CHIAVI INCLUDE Keys included Schluesssel inbegriffen			
MZT0040116	ERA16	1:1	6000	20Nm	-	X	CHUB19_SP3	CHUB32	CHESL05	CHTAER16ZC
MZT0040216	ERA16	1:1	6000	20Nm	P=70bar	X	CHUB19_SP3	CHUB32	CHESL05	CHTAER16ZC

DMG-MORI
MOD: ZT1000/1500 12/16 STAZIONI

MODULO MOTORIZZATO ORIENTABILE ±90°
±90° adjustable angle driven tool
Angetriebenes Werkzeug schwenkbar ±90°

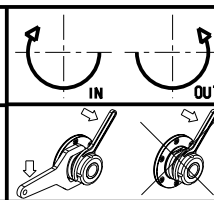

M.T. srl
Via Casino Albini 480
Tel. 0541/956034-957884
Fax 0541/956341
47842 S. GIOVANNI IN M. (RN)
e-mail: mtma@mtmarchetti.com
http://www.mtmarchetti.com



MZT335-1-10

Subject to change without notice.

03/2024