

**ATTENZIONE - ATTENTION - ACHTUNG**

- Per lo smontaggio degli utensili utilizzare sempre la chiave di contrasto come indicato nel manuale d'uso.
- For disassembly of the tools use always the contrast key as mentioned in the user instructions.
- Fuer das Abmontieren der Werkzeuge immer den Gegenschuessel benutzen wie in der Bedienungsanleitung erwaehnt.

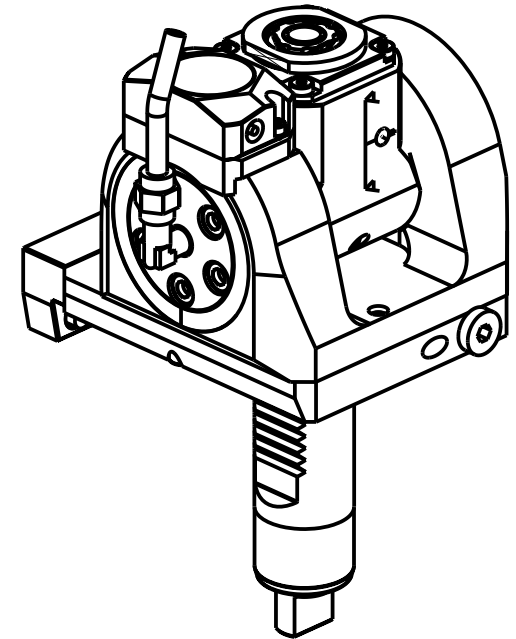

Cod. MT	Mandrino Spindle Spindel	I	RPM	Coppia Max Max Torque Max Drehmoment	Lubrificazione int. Coolant through Innenkuehlung	Lubrificazione est. Ext. coolant Aussenkuehlung	CHIAVI INCLUSE Keys included Schuessel inbegriffen		
MZT0055316	ERA16	1:2	12000	8Nm	-	X	CHUB19_SP3	CHUB32	CHTAER16ZC
MZT0055416	ERA16	1:2	12000	8Nm	P=70bar	X	CHUB19_SP3	CHUB32	CHTAER16ZC

DMG-MORI  
MOD: ZT1000/1500 12 STAZIONI

MODULO MOTORIZZATO ORIENTABILE  $\pm 90^\circ$  MOLTIPLICATO 1=1:2 CON NONIO DIGITALE  
 $\pm 90^\circ$  adjustable angle driven tool geared-up 1=1:2 with digital display  
 Angetriebenes Werkzeug schwenkbar  $\pm 90^\circ$  uebersetzt 1=1:2 mit digital display

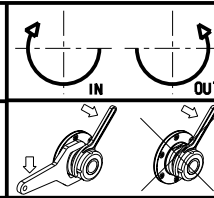

**M.T. srl**  
 Via Casino Albini 480  
 Tel. 0541/956034-957884  
 Fax 0541/956341  
 47842 S. GIOVANNI IN M. (RN)  
 e-mail: mtma@mtmarchetti.com  
 http://www.mtmarchetti.com



MZT336-1-01

Subject to change without notice.

03/2024