

-Solo questa uscita è con lubrificazione interna.  
 -Only this outlet is with internal coolant.  
 -Nur dieser Ausgang ist mit IKZ.

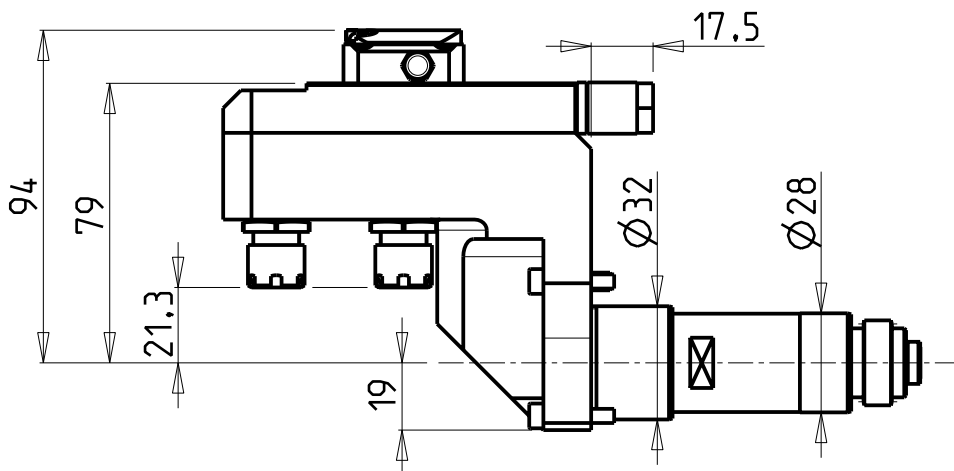

**ATTENZIONE - ATTENTION - ACHTUNG**

- Per lo smontaggio degli utensili utilizzare sempre la chiave di contrasto come indicato nel manuale d'uso.
- For disassembly of the tools use always the contrast key as mentioned in the user instructions.
- Fuer das Abmontieren der Werkzeuge immer den Gegenschlüssel benutzen wie in der Bedienungsanleitung erwaeht.

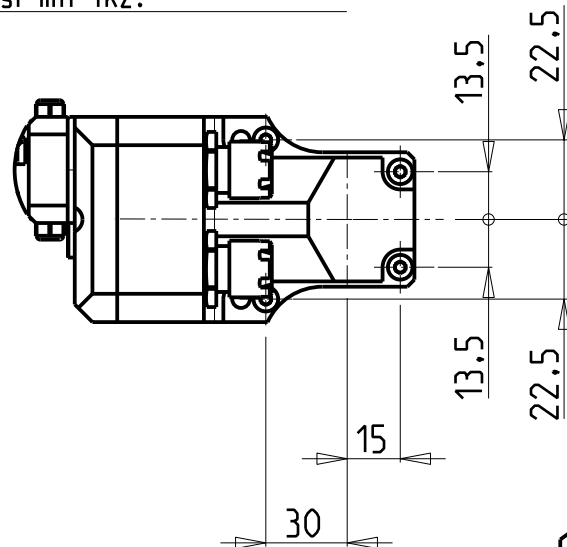
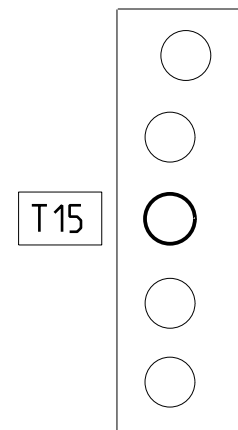
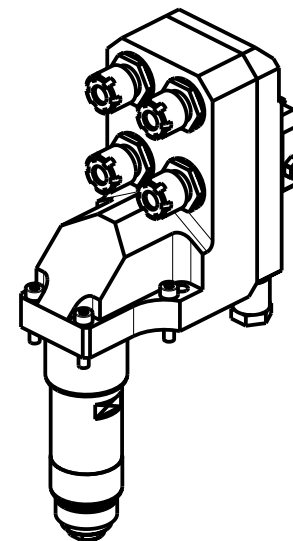

T15

Cod. MT	Mandrino Spindle Spindel	I	RPM	N°Utensili N°Tools N°Werkzeuge	Lubrificazione int. Coolant through Innenkuehlung	Lubr.esterna Ext. coolant Aussenkuehlung	CHIAVI NON INCLUDE Keys not included Schluessel nicht einbegriffen	
NMR0100111	ER11	1:2	12000	4	P=25bar	X	CHMNER11	CHUB19_SP3

NOMURA  
 MOD: NN20J - NN20J2 - NN20JS

MODULO MOTORIZZATO ASSIALE 4 USCITE MOLTIPLICATO I=1:2  
 Axial geared-up I=1:2 multiple 4 outlet driven tool  
 Axial angetriebenes Mehrspindel-Werkzeug 4 Ausgaenge uebersetzt I=1:2

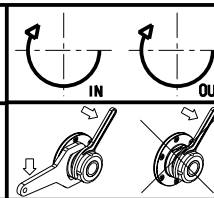

**M.T. srl**  
 Via Casino Albini 480  
 Tel. 0541/956034-957884  
 Fax 0541/956341  
 47842 S. GIOVANNI IN M. (RN)  
 e-mail: mtma@mtmarchetti.com  
 http://www.mtmarchetti.com

**MT**

NOM271-1-00

Subject to change without notice.