

ATTENZIONE - ATTENTION - ACHTUNG

- Per lo smontaggio degli utensili utilizzare sempre la chiave di contrasto come indicato nel manuale d'uso.
- For disassembly of the tools use always the contrast key as mentioned in the user instructions.
- Fuer das Abmontieren der Werkzeuge immer den Gegenschlüssel benutzen wie in der Bedienungsanleitung erwaeht.

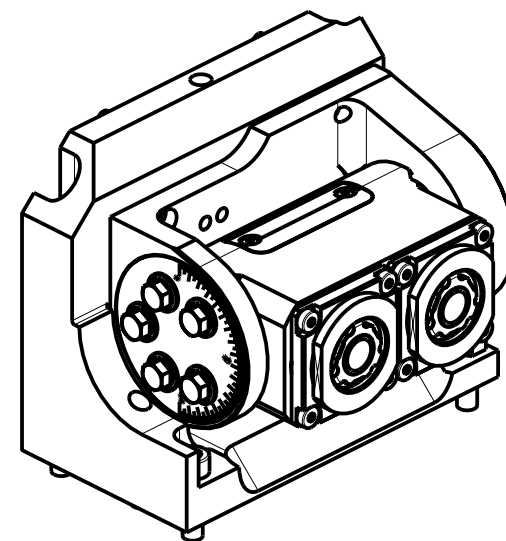

Cod. MT	Mandrino Spindle Spindel	I	RPM	Lubrificazione est. Ext. coolant Aussenkuehlung	CHIAVI INCLUSE Keys included Schlüssel inbegriffen			
NMR0020216	ERA16	1:1	6000	X	CHUB32	CHUB19_SP3	CHTAER16ZC	CH_POLIG_08

NOMURA
MOD: NN20J - NN20J2 - NN20JS

MODULO MOTORIZZATO ORIENTABILE DOPPIO ±90° PER CONTROMANDRINO
 ±90° double adjustable angle driven tool for subspindle
 Doppel-Angetriebenes Werkzeug schwenkbar ±90° fuer Gegenspindel

Subject to change without notice.

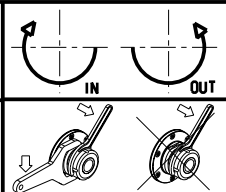

M.T. srl
 Via Casino Albini 480
 Tel. 0541/956034-957884
 Fax 0541/956341
 47842 S. GIOVANNI IN M. (RN)
 e-mail: mtma@mtmarchetti.com
 http://www.mtmarchetti.com



NOM338-1-10