

### ATTENZIONE - ATTENTION - ACHTUNG

- Per lo smontaggio degli utensili utilizzare sempre la chiave di contrasto come indicato nel manuale d'uso.
- For disassembly of the tools use always the contrast key as mentioned in the user instructions.
- Fuer das Abmontieren der Werkzeuge immer den Gegenschlüssel benutzen wie in der Bedienungsanleitung erwaeht.

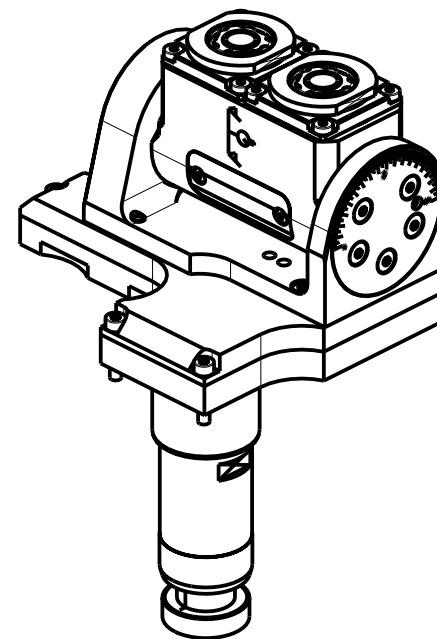

T13

Cod. MT	Mandrino Spindle Spindel	I	RPM	Lubrificazione est. Ext. coolant Aussenkuehlung	CHIAVI INCLUSE Keys included Schlüssel inbegriffen		
NMR0030216	ERA16	1:1	6000	X	CHUB32	CHUB19_SP3	CHTAER16ZC

NOMURA  
MOD: NN32YB2

MODULO MOTORIZZATO ORIENTABILE DOPPIO ±90°  
±90° double adjustable angle driven tool  
Doppel-Angetriebenes Werkzeug schwenkbar ±90°

Subject to change without notice.

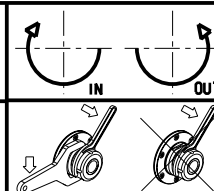

**M.T. srl**  
Via Casino Albini 480  
Tel. 0541/956034-957884  
Fax 0541/956341  
47842 S. GIOVANNI IN M. (RN)  
e-mail: mtma@mtmarchetti.com  
http://www.mtmarchetti.com



NOM338-2-00

03/2024