

4
Piano Inserti
Inserts Surface
Einsätze Fläche

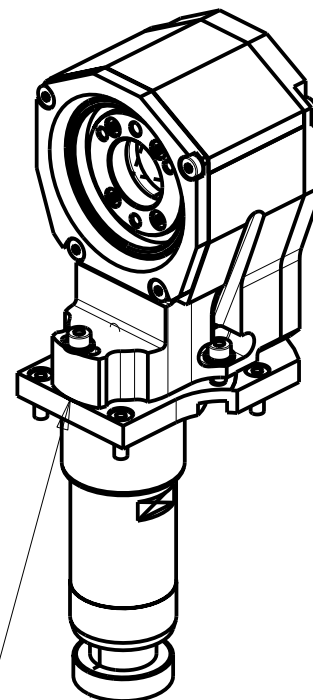

INCLINAZIONE
REGOLABILE $\pm 15^\circ$

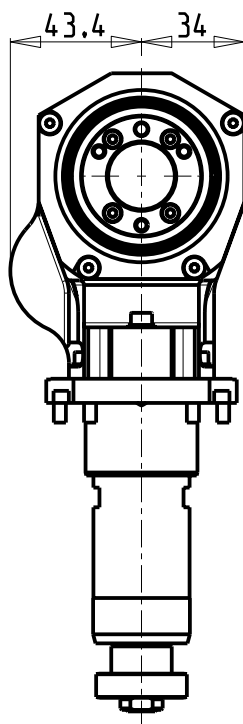
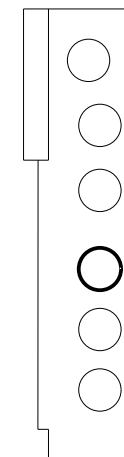
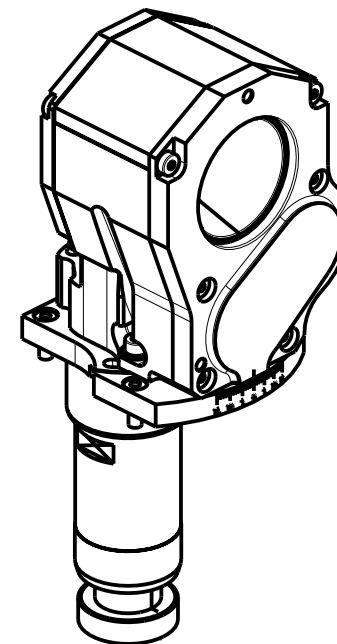

T13

Cod. MT	I	RPM	Lubrificazione est. Ext. coolant Aussenkuehlung
NMR0070112	2:1	3000	X

Fresa non inclusa:
Milling-cutter not included:
Fraese nicht inbegriffen:
SANDVIK Coromill 325 cod. 325-12AP40-16M

NOMURA

MOD: NN32YB2

MODULO MOTORIZZATO TURBINATORE RIDOTTO I=2:1

Driven whirling tool geared-down I=2:1

Gewindewirbeleinrichtung untersetzt I=2:1

Subject to change without notice.

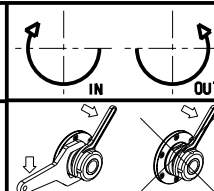

M.T. srl

Via Casino Albini 480
Tel. 0541/956034-957884

Fax 0541/956341

47842 S. GIOVANNI IN M. (RN)

e-mail: mtma@mtmarchetti.com

http://www.mtmarchetti.com



NOM370-2-00

03/2024