

- Chiave inclusa
- Key included
- Schluessel inbegriffen

ATTENZIONE - ATTENTION - ACHTUNG

- Per lo smontaggio degli utensili utilizzare sempre la chiave di contrasto come indicato nel manuale d'uso.
- For disassembly of the tools use always the contrast key as mentioned in the user instructions.
- Fuer das Abmontieren der Werkzeuge immer den Gegenschluessel benutzen wie in der Bedienungsanleitung erwaehnt.

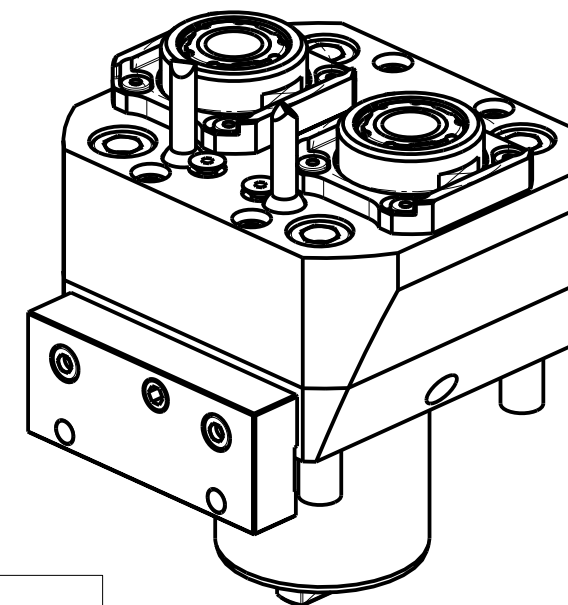

| Cod. MT | Mandrino Spindle Spindel | I | RPM | Coppia Max Max Torque Max Drehmoment | Lubrificazione int. Coolant through Innenkuehlung | Lubrificazione est. Ext. coolant Aussenkuehlung | CHIAVI NON INCLUDE Keys not included Schluessel nicht einbegriffen | | |
|------------|--------------------------|-----|------|--------------------------------------|---|---|--|--------------|--------------|
| OKU0450125 | ERA25 | 1:1 | 6000 | 40Nm | | X | CHUB27 | CHTAER25ZC • | OKU0290009 • |
| OKU0450225 | ERA25 | 1:1 | 6000 | 40Nm | P=70bar | X | CHUB27 | CHTAER25ZC • | OKU0290009 • |

OKUMA

MOD: LB4000EX(I) - LB4000EX(II) - LU4000EX

MODULO MOTORIZZATO RADIALE 2 USCITE IN Y

Radial single side twin head driven tool in Y

Radial angetriebenes Werkzeug 2 Ausgaenge in Y

Subject to change without notice.

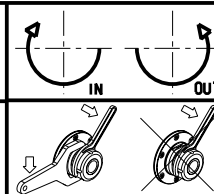

M.T. srl

Via Casino Albini 480
Tel. 0541/956034-957884
Fax 0541/956341
47842 S. GIOVANNI IN M. (RN)
e-mail: mtma@mtmarchetti.com
http://www.mtmarchetti.com



OKU080-5-00