

PER LAVORAZIONI INTERNE
SU FORI Ø65 MINIMO

For machining internal
holes with Ø65 min. hole

Fuer interne Bearbeitungen
am loch minimum Ø65

ATTENZIONE - ATTENTION - ACHTUNG

- Per lo smontaggio degli utensili utilizzare sempre la chiave di contrasto come indicato nel manuale d'uso.
- For disassembly of the tools use always the contrast key as mentioned in the user instructions.
- Fuer das Abmontieren der Werkzeuge immer den Gegenschlüssel benutzen wie in der Bedienungsanleitung erwaeht.

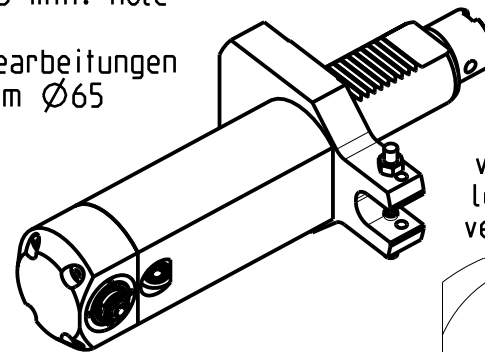
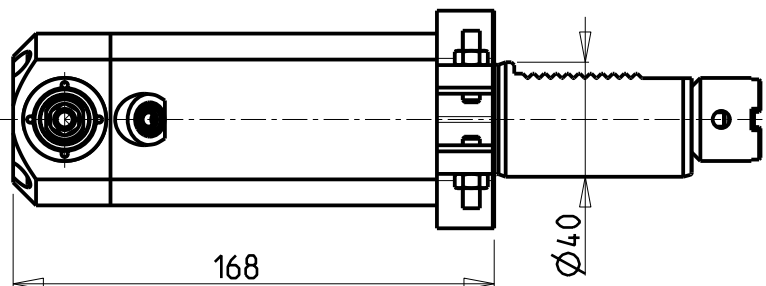

versione sx
left version
version links

versione dx
right version
version rechts

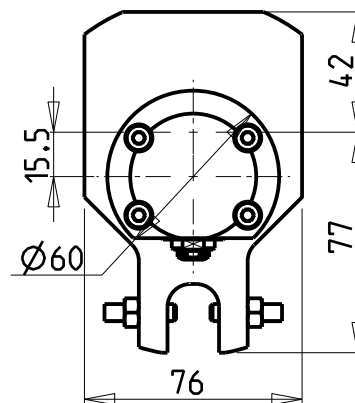
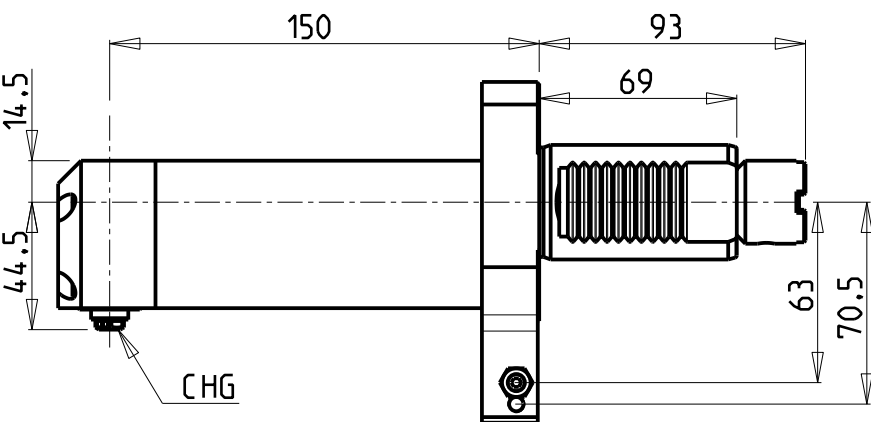
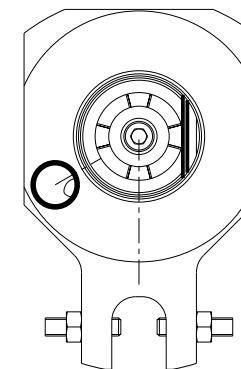
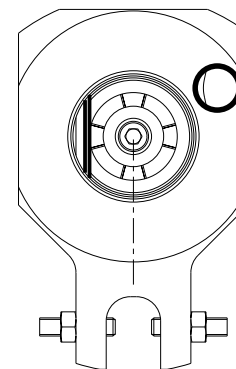

**TORRETTE ASSIALI
AXIAL TURRETS
AXIAL REVOLVER**

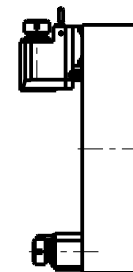

Cod. MT		Mandrino Spindle Spindel	I	RPM	Coppia Max Max Torque Max Drehmoment	Lubrificazione est. Ext. coolant Aussenkuehlung	CHIAVI INCLUSE Keys included Schlüssel einbegriffen	
versione sx left version version links	versione dx right version version rechts						CHUB13_SP3	CHCHG10
1270KU_R10_40B00	1270KU_R10_40B10	CHG	1:1	4000	10Nm	X	CHUB13_SP3	CHCHG10

OKUMA
MOD: LB15/300 - LT15/300 - LR15 - LU15M - LU300M - GENOS L300M - GENOS L3000e M/MY (VDI40) - ES L10M

MODULO MOTORIZZATO RADIALE VDI40 H=150mm
Radial driven tool VDI40 H=150mm
Radial angetriebenes Werkzeug VDI40 H=150mm

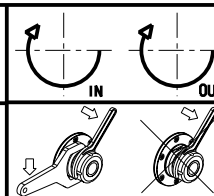

M.T. srl
Via Casino Albini 480
Tel. 0541/956034-957884
Fax 0541/956341
47842 S. GIOVANNI IN M. (RN)
e-mail: mtma@mtmarchetti.com
http://www.mtmarchetti.com



OKU125-2-00

Subject to change without notice.

03/2024