

**TORRETTE RADIALI
RADIAL TURRETS
RADIAL REVOLVER**

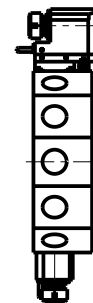

ATTENZIONE - ATTENTION - ACHTUNG

- Per lo smontaggio degli utensili utilizzare sempre la chiave di contrasto come indicato nel manuale d'uso.
- For disassembly of the tools use always the contrast key as mentioned in the user instructions.
- Fuer das Abmontieren der Werkzeuge immer den Gegenschlüssel benutzen wie in der Bedienungsanleitung erwaeht.

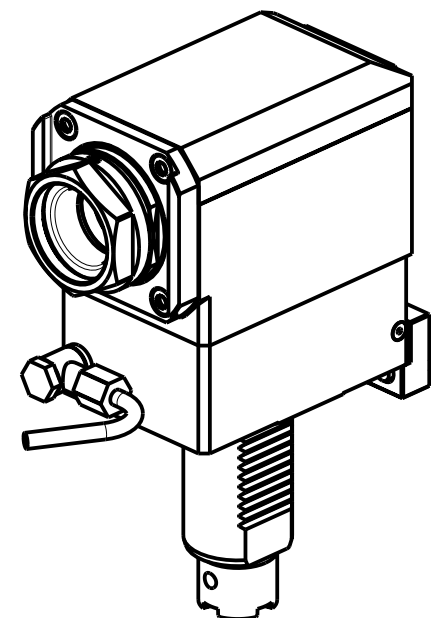

- Chiave inclusa
- Key included
- Schluessel inbegriffen

PER PORTAUTENSILI MODULARI MTSK-40 VEDI PAG. TBL300-1-40
FOR MTSK-40 QUICK CHANGE TOOLHOLDERS CLAMPINGS SEE PAGE TBL300-1-40
FUER MTSK-40 MODULARE WERKZEUGAUFNAHMEN SIEHE SEITE TBL300-1-40

Cod. MT	Mandrino Spindle Spindel	I	RPM	Coppia Max Max Torque Max Drehmoment	Lubrificazione int. Coolant through Innenkuehlung	Lubrificazione est. Ext. coolant Aussenkuehlung	B	CHIAVI NON INCLUSE Keys not included Schluessel nicht einbegriffen	
OKU0660140	MTSK-40	1:1	4000	70Nm	-	X	58.5	CHUB46	OKU0650004 ▪
OKU0660240	MTSK-40	1:1	4000	70Nm	P=70bar	X	69.5	CHUB46	OKU0650004 ▪

OKUMA
MOD: LB15/300 - LT15/300 - LR15 - LU15M - LU300M - MACTURN 250/350/550

MODULO MOTORIZZATO ASSIALE MTSK PER CONTROMANDRINO VDI40 H=90mm
Axial MTSK driven tool for subspindle VDI40 H=90mm
Axial MTSK angetriebenes Werkzeug fuer Gegenspindel VDI40 H=90mm

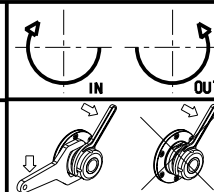

M.T. srl
Via Casino Albini 480
Tel. 0541/956034-957884
Fax 0541/956341
47842 S. GIOVANNI IN M. (RN)
e-mail: mtma@mtmarchetti.com
http://www.mtmarchetti.com



OKU155-2-10-K