

ATTENZIONE - ATTENTION - ACHTUNG

- Per lo smontaggio degli utensili utilizzare sempre la chiave di contrasto come indicato nel manuale d'uso.
- For disassembly of the tools use always the contrast key as mentioned in the user instructions.
- Fuer das Abmontieren der Werkzeuge immer den Gegenschlüssel benutzen wie in der Bedienungsanleitung erwaeht.

**TORRETTE ASSIALI
AXIAL TURRETS
AXIAL REVOLVER**

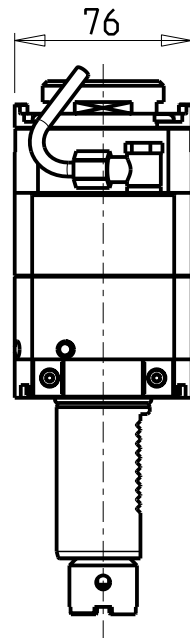
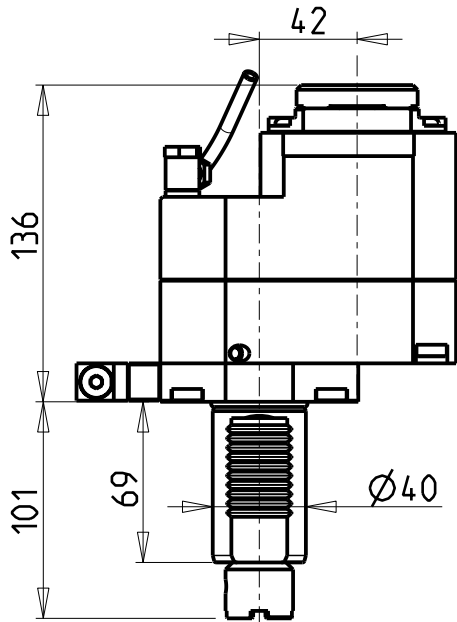
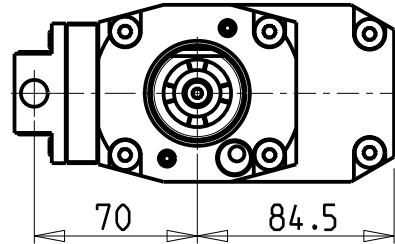
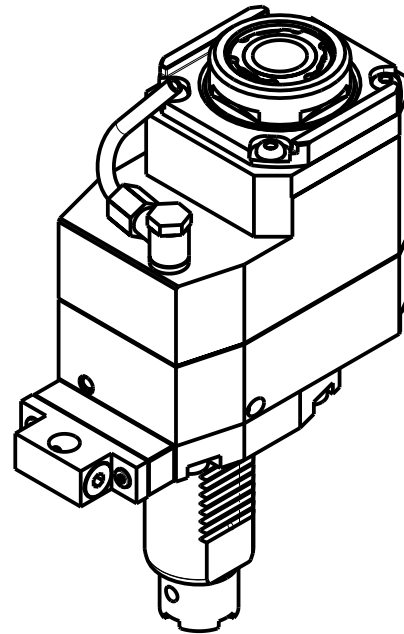
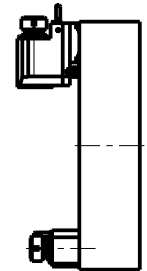

- Chiave inclusa
- Key included
- Schluessel inbegriffen

Cod. MT	Mandrino Spindle Spindel	I	RPM	Coppia Max Max Torque Max Drehmoment	Lubrificazione int. Coolant through Innenkuehlung	Lubrificazione est. Ext. coolant Aussenkuehlung	CHIAVI NON INCLUSE Keys not included Schluessel nicht einbegriffen		
OKU1207132	ERA32	1:2	8000	45Nm	-	X	CHUB30	CHTAER32ZC	OKU0650004
OKU1207232	ERA32	1:2	8000	45Nm	P=70bar	X	CHUB30	CHTAER32ZC	OKU0650004

OKUMA
MOD: LB25/400 - LR25 - LU25M - LU400M

MODULO MOTORIZZATO ASSIALE MOLTIPLICATO I=1:2 DISASSATO 42mm VD140
Axial geared-up I=1:2 driven tool re-directed by 42mm VD140
Axial angetriebenes Werkzeug uebersetzt I=1:2 achsversetzt um 42mm VD140

Subject to change without notice.

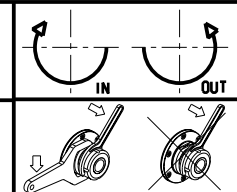

M.T. srl
Via Casino Albini 480
Tel. 0541/956034-957884
Fax 0541/956341
47842 S. GIOVANNI IN M. (RN)
e-mail: mtma@mtmarchetti.com
http://www.mtmarchetti.com



OKU160-3-20