

**ATTENZIONE - ATTENTION - ACHTUNG**

- Per lo smontaggio degli utensili utilizzare sempre la chiave di contrasto come indicato nel manuale d'uso.
- For disassembly of the tools use always the contrast key as mentioned in the user instructions.
- Fuer das Abmontieren der Werkzeuge immer den Gegenschlüssel benutzen wie in der Bedienungsanleitung erwaeht.

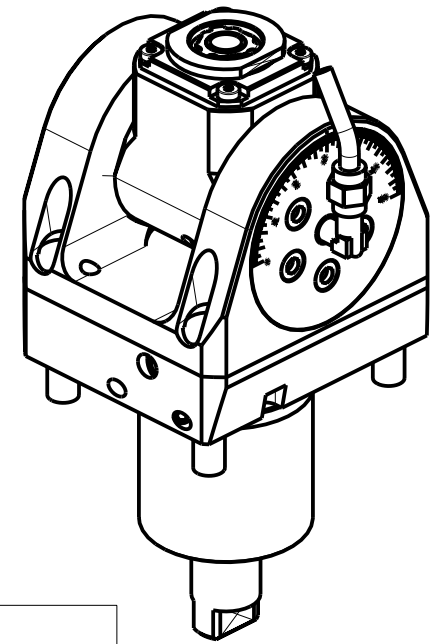

Cod. MT	Mandrino Spindle Spindel	I	RPM	Coppia Max Max Torque Max Drehmoment	Lubrificazione int. Coolant through Innenkuehlung	Lubrificazione est. Ext. coolant Aussenkuehlung	CHIAVI INCLUSE Keys included Schluessel inbegriffen			
OKU0810316	ERA16	1:2	12000	8Nm		X	CHUB19_SP3	CHUB32	CHTAER16ZC	CHESL07
OKU0810416	ERA16	1:2	12000	8Nm	P=70bar	X	CHUB19_SP3	CHUB32	CHTAER16ZC	CHESL07

**OKUMA**  
MOD: LT2000EX 16ST.

MODULO MOTORIZZATO ORIENTABILE +/-90° MOLTIPLICATO I=1:2 H=60mm  
 +/-90° adjustable angle driven tool geared-up I=1:2 H=60mm  
 Angetriebenes Werkzeug schwenkbar +/-90° uebersetzt I=1:2 H=60mm

Subject to change without notice.

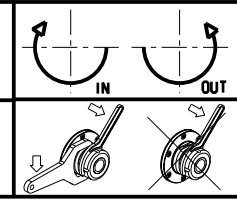

**M.T. srl**  
 Via Casino Albini 480  
 Tel. 0541/956034-957884  
 Fax 0541/956341  
 47842 S. GIOVANNI IN M. (RN)  
 e-mail: mtma@mtmarchetti.com  
 http://www.mtmarchetti.com



OKU336-6-00