

ATTENZIONE - ATTENTION - ACHTUNG

- VERIFICARE LE MISURE DI INGOMBRO PER POSSIBILE INTERFERENZA SU ALCUNI MODELLI DI MACCHINE
- Please check the overall sizes for possible interferences on some machine models
- Bitte überprüfen sie das ausmass um mögliche interferenzen auf einigen maschinen modellen zu vermeiden

-LA FUNZIONE DI POLIGONATURA/DENTATURA DEVE ESSERE INSTALLATA SULLA MACCHINA
 -POLYGON CUTTING/GEAR HOBBING FUNCTION MUST BE INSTALLED ON THE MACHINE
 -DIE FUNKTION FÜR POLYGON-BZW. VERZÄHNUNGSFRÄSEN MUSS AUF DER MASCHINE FREIGESCHALTET WERDEN

**TORRETTE ASSIALI
 AXIAL TURRETS
 AXIAL REVOLVER**

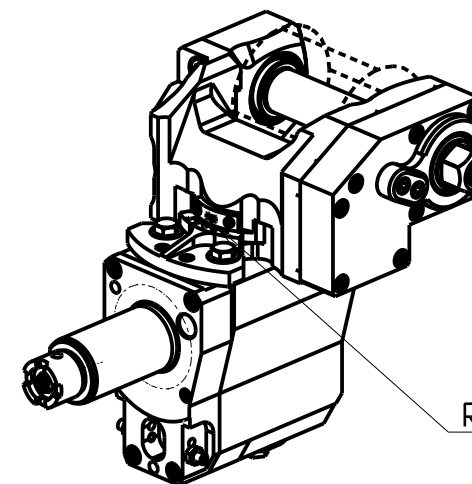
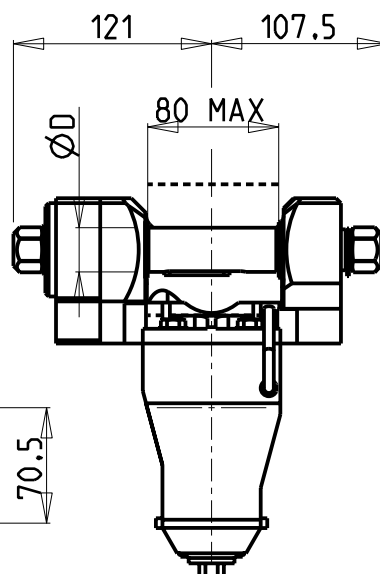
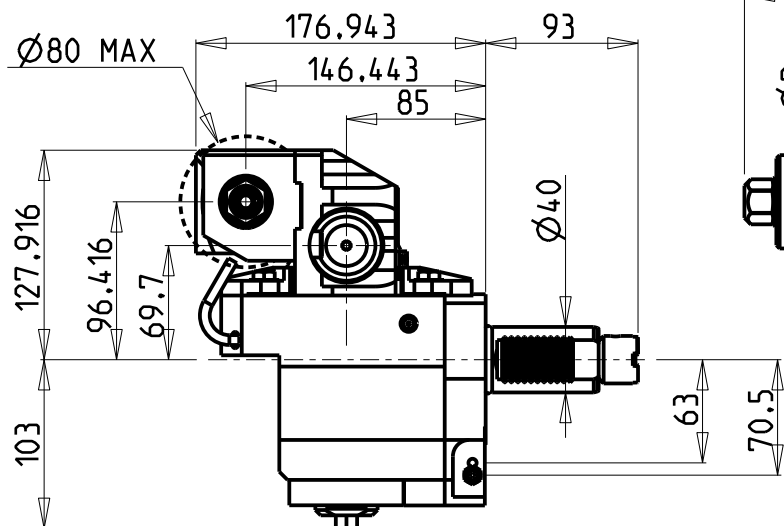
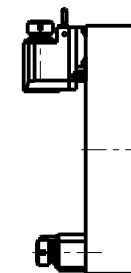

INCLINAZIONE
 REGOLABILE ±20°

PER ALBERI E DISTANZIALI VEDI PAG. TBL250-1-00
 FOR SHAFT END SPACER SEE PAGE TBL250-1-00
 FUER DORN UND ABSTANDSSTUECK SEITE TBL250-1-00

DOTAZIONI - SUPPLIED WITH - AUSSTATTUNG

mm / inch	
	- N°1 ALBERO + DISTANZIALI
	- N°1 SHAFT + SPACER
	- N°1 DORN + ABSTANDSSTUECK

Cod. MT	I	RPM	Coppia Max Max Torque Max Drehmoment	Lubrificazione est. Ext. coolant Aussenkuehlung	D (mm)	D (Inch)	CHIAVI INCLUSE Keys included Schlüssel einbegriffen		
OKU1771110	1:1	6000	60Nm	X	16-22-27-32	3/4"-1"-1 1/4"	CHUB24	CHUB13	CHESL08
OKU1772110	2:1	3000	80Nm	X	16-22-27-32	3/4"-1"-1 1/4"	CHUB24	CHUB13	CHESL08

OKUMA
 MOD: LB15/300 - LT15/300 - LR15 - LU15M - LU300M - GENOS L300M - GENOS L3000e M/MY (VDI40) - ES L10M

MODULO MOTORIZZATO PORTACREATORE VDI40
 Driven gear hobber VDI40
 Angetriebenes Zahnradwaelzfraes-Werkzeug VDI40

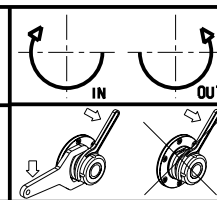

M.T. srl
 Via Casino Albini 480
 Tel. 0541/956034-957884
 Fax 0541/956341
 47842 S. GIOVANNI IN M. (RN)
 e-mail: mtma@tmarchetti.com
 http://www.tmmarchetti.com

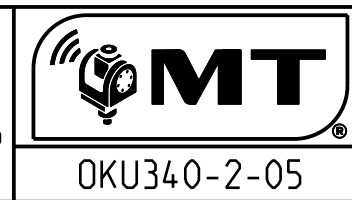

Subject to change without notice.