

-LA FUNZIONE DI POLIGONATURA/DENTATURA DEVE ESSERE INSTALLATA SULLA MACCHINA  
 -POLYGON CUTTING/GEAR HOBGING FUNCTION MUST BE INSTALLED ON THE MACHINE  
 -DIE FUNKTION FÜR POLYGON-BZW. VERZÄHNUNGSFRÄSEN MUSS AUF DER MASCHINE FREIGESCHALTET WERDEN

versione dx  
 right version  
 version rechts

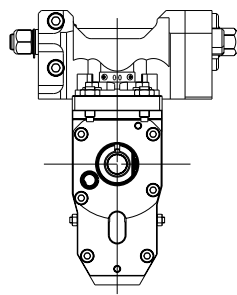

versione universale  
 universal version  
 universal version

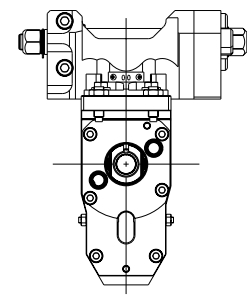

**TORRETTE ASSIALI**  
**AXIAL TURRETS**  
**AXIAL REVOLVER**

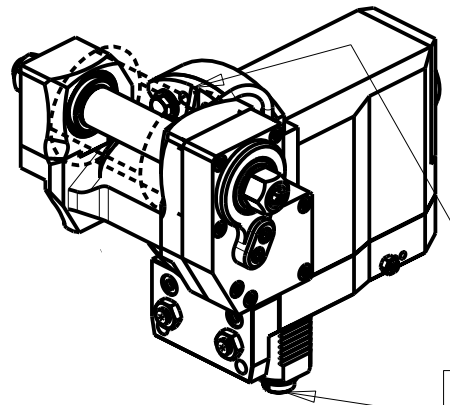
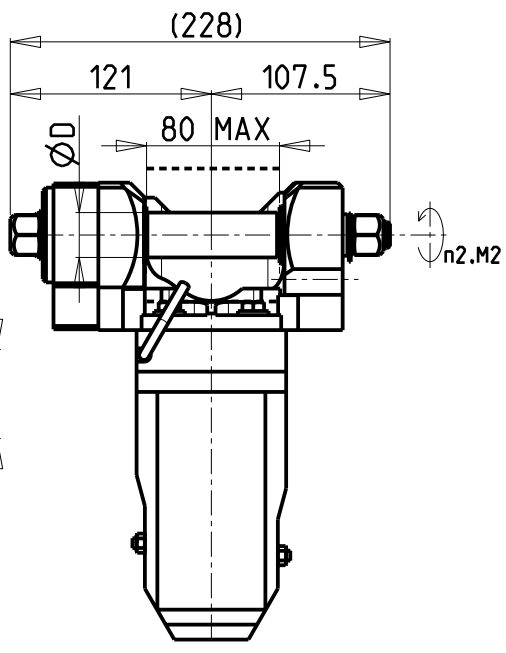
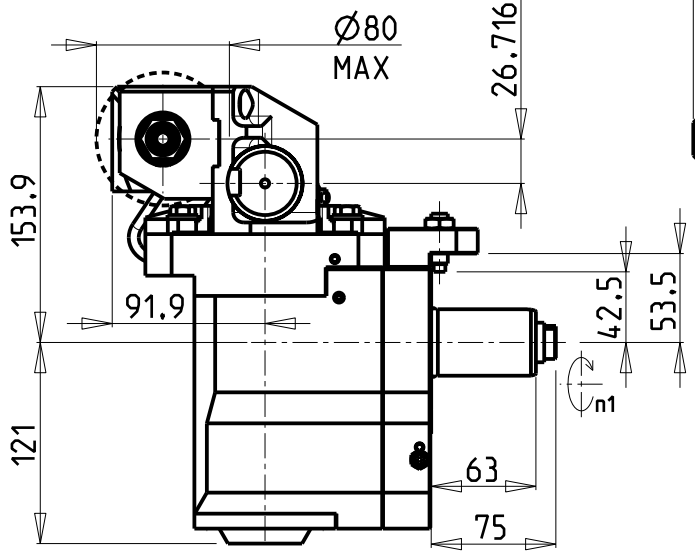
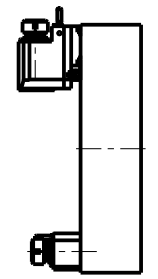

INCLINAZIONE  
 REGOLABILE ±20°

DIN 5480

PER ALBERI E DISTANZIALI VEDI PAG. TBL250-1-00  
 FOR SHAFT END SPACER SEE PAGE TBL250-1-00  
 FUER DORN UND ABSTANDSSTUECK SEITE TBL250-1-00

Cod. MT		I (n1:n2)	RPM max n2	Coppia Max Max Torque Max Drehmoment M2 (Nm)	Lubr.esterna Ext. coolant Aussenkuehlung	D (mm)	D (Inch)	CHIAVI INCLUSE Keys included Schlüssel einbegriffen		
versione dx right version version rechts	versione universale universal version universal version							C HUB24	C HUB13	C HESL08
SAU0011140	SAU0015140	1:1	6000	60	X	16-22-27-32	3/4"-1"-1 1/4"	C HUB24	C HUB13	C HESL08
SAU0012140	SAU0016140	2:1	3000	80	X	16-22-27-32	3/4"-1"-1 1/4"	C HUB24	C HUB13	C HESL08

DOTAZIONI - SUPPLIED WITH - AUSSTATTUNG	
mm / inch	- N°1 ALBERO + DISTANZIALI - N°1 SHAFT + SPACER - N°1 DORN + ABSTANDSSTUECK

SAUTER  
 VDI 40  
 MODULO MOTORIZZATO PORTACREATORE VDI40 DIN 5480  
 Driven gear hobber VDI40 DIN 5480  
 Angetriebenes Zahnradwaelzfraes-Werkzeug VDI40 DIN 5480

**M.T. srl**  
 Via Casino Albini 480  
 Tel. 0541/956034-957884  
 Fax 0541/956341  
 47842 S. GIOVANNI IN M. (RN)  
 e-mail: mtma@mtmarchetti.com  
 http://www.mtmarchetti.com



SAU340-3-00

Subject to change without notice.