

versione dx
right version
version rechts

versione sx
left version
version links

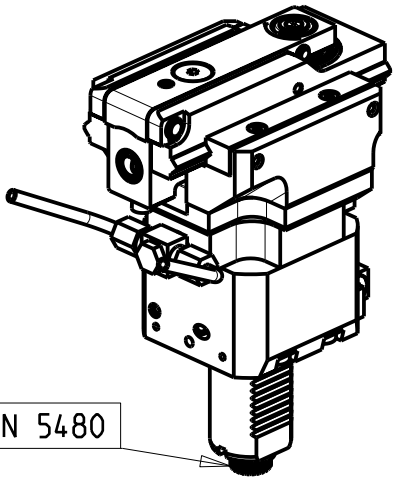

DIN 5480

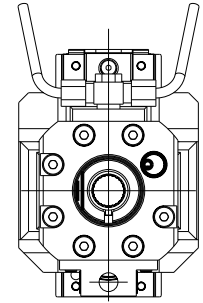
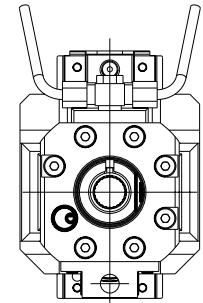
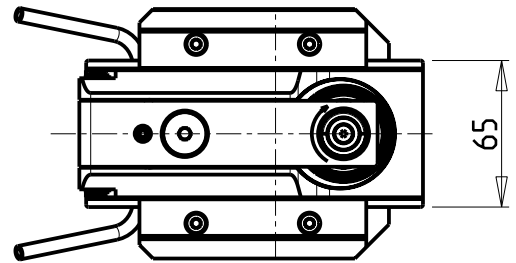
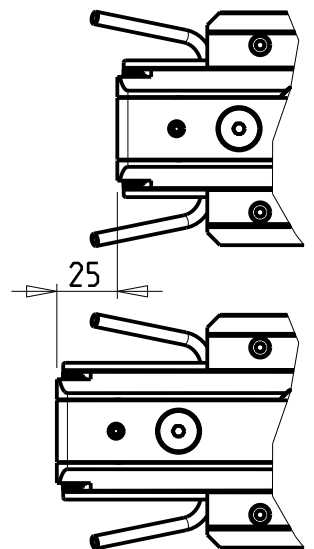

DOTAZIONI - SUPPLIED WITH - AUSSTATTUNG

N°1 Boccola di riduz. Ø16-Ø12 e N°1 Boccola di riduz. Ø16-Ø10
 N°1 Reduction bush Ø16-Ø12 and N°1 Reduction bush Ø16-Ø10
 N°1 Reduzierbuchsen Ø16-Ø12 und N°1 Reduzierbuchsen Ø16-Ø10

PER UTENSILI STOZZATORI VEDI PAG. TBL400-1-00
 FOR DRIVEN SLOTTING TOOL CUTTING-TOOLS SEE PAGE TBL400-1-00
 FÜR NUTENSTOSS-WERKZEUG SCHNEIDWERKZEUGE SIEHE SEITE TBL400-1-00

Cod. MT		I	RPM MAX	Lubr. esterna Ext. coolant Aussenkuehlung
versione dx right version version rechts	versione sx left version version links			
SAU0720200	SAU0721200	4:1	2400	X

SAUTER
VDI 40

MODULO MOTORIZZATO STOZZATORE CORSA 25mm H=120mm VDI40 DIN 5480
 Slotting driven tool 25mm stroke H=120mm VDI40 DIN 5480
 Keilnutenstossmaschine 25mm Hub H=120mm VDI40 DIN 5480

M.T. srl
 Via Casino Albini 480
 Tel. 0541/956034-957884
 Fax 0541/956341
 47842 S. GIOVANNI IN M. (RN)
 e-mail: mtma@mtmarchetti.com
 http://www.mtmarchetti.com



SAU360-3-01

Subject to change without notice.

03/2024