

versione sx  
left version  
version links

versione dx  
right version  
version rechts

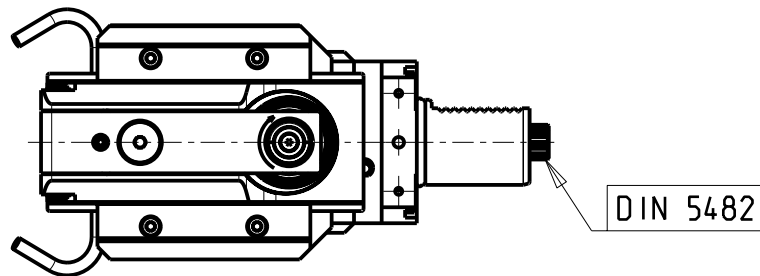

**TORRETTE ASSIALI  
AXIAL TURRETS  
AXIAL REVOLVER**

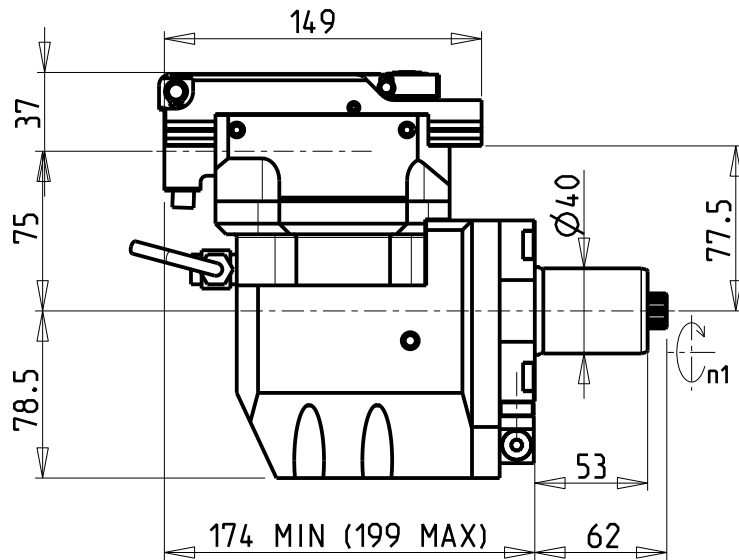
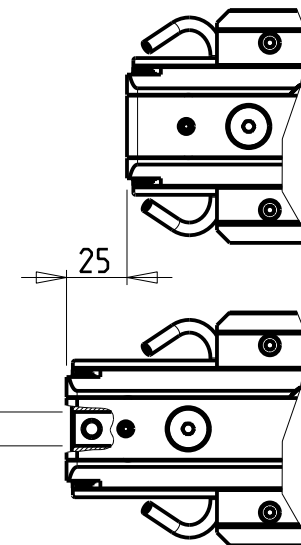
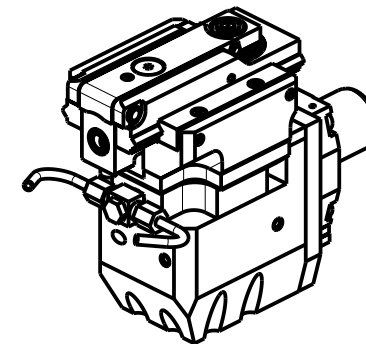
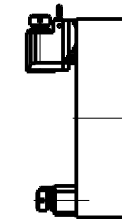

**DOTAZIONI - SUPPLIED WITH - AUSSTATTUNG**

N°1 Boccia di riduz. Ø16-Ø12 e N°1 Boccia di riduz. Ø16-Ø10  
N°1 Reduction bush Ø16-Ø12 and N°1 Reduction bush Ø16-Ø10  
N°1 Reduzierbuchsen Ø16-Ø12 und N°1 Reduzierbuchsen Ø16-Ø10

PER UTENSILI STOZZATORI VEDI PAG. TBL400-1-00  
FOR DRIVEN SLOTTING TOOL CUTTING-TOOLS SEE PAGE TBL400-1-00  
FÜR NUTENSTOSS-WERKZEUG SCHNEIDWERKZEUGE SIEHE SEITE TBL400-1-00

Cod. MT		I	RPM max n1	Lubr. esterna Ext. coolant Aussenkuehlung	Lav. secco Dry-run Trocken Bearb.
versione dx right version version rechts	versione sx left version version links				
SAU0740200	SAU0741200	4:1	2400	X	-

SAUTER  
VDI 40

MODULO MOTORIZZATO STOZZATORE CORSA 25mm VDI40 DIN 5482  
Slotting driven tool 25mm stroke VDI40 DIN 5482  
Keilnutenstossmaschine 25mm Hub VDI40 DIN 5482

**M.T. srl**

Via Casino Albini 480  
Tel. 0541/956034-957884  
Fax 0541/956341  
47842 S. GIOVANNI IN M. (RN)  
e-mail: mtma@mtmarchetti.com  
http://www.mtmarchetti.com



SAU360-3-81

Subject to change without notice.

03/2026