

## ATTENZIONE - ATTENTION - ACHTUNG

- VERIFICARE LE MISURE DI INGOMBRO PER POSSIBILE INTERFERENZA SU ALCUNI MODELLI DI MACCHINE
- Please check the overall sizes for possible interferences on some machine models
- Bitte überprüfen sie das ausmass um mögliche interferenzen auf einigen maschinen modellen zu vermeiden

- Chiave inclusa
- Key included
- Schlüssel inbegriffen

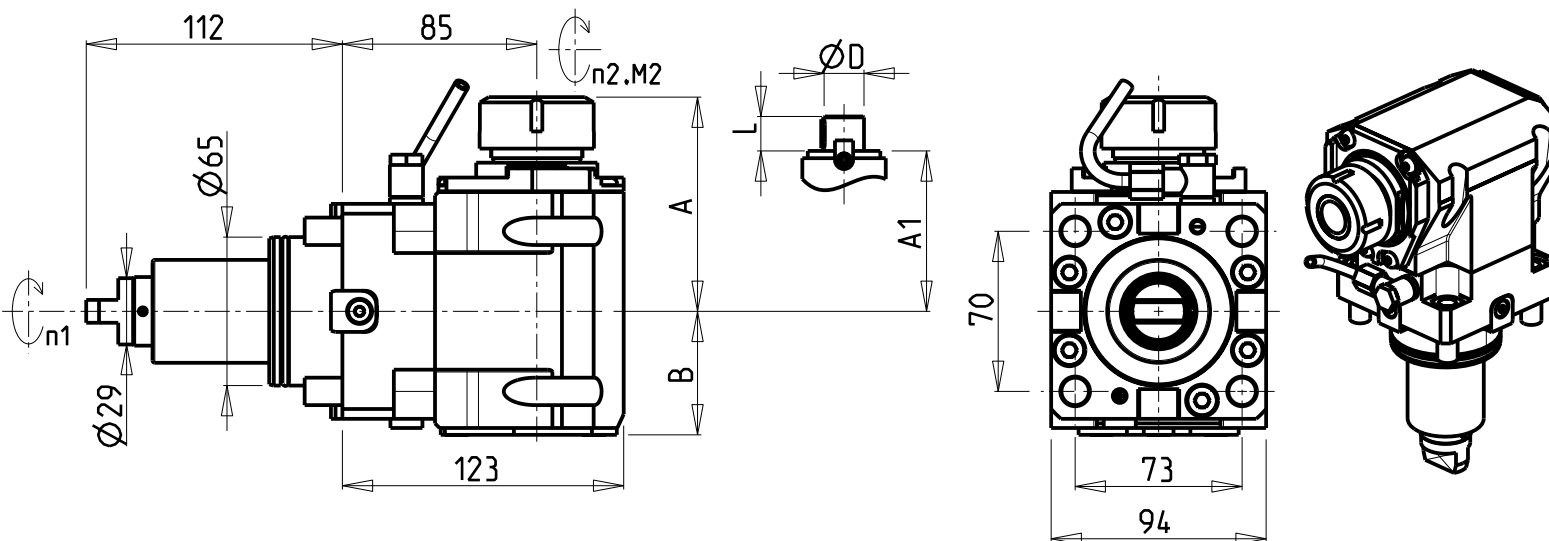

Cod. MT	Mandrino Spindle Spindel	I (n1:n2)	RPM max n2	Coppia Max Max Torque Max Drehmoment M2 (Nm)	Reversibile lato mandrino/contromandrino Reversible sub/main spindle side Umkehrbare Spindel-seite/ Gegenspindel-seite	Lubrificazione int. Coolant through Innenkuehlung Pmax (bar)	Lubr.esterna Ext. coolant Aussenkuehlung	A	A1	B	D	L	CHIAVI NON INCLUSE Keys not included Schluessel nicht einbegriffen
DW 01130125	ER25	1:1	6000	100	X	-	X	91.16	-	54	-	-	CHSTER25 OKU0650004
DW 01130225	ER25	1:1	6000	100	X	70	X	91.16	-	65	-	-	CHSTER25 OKU0650004
DW 01130132	ER32	1:1	6000	100	X	-	X	93.66	-	54	-	-	CHSTER32 OKU0650004
DW 01130232	ER32	1:1	6000	100	X	70	X	93.66	-	65	-	-	CHSTER32 OKU0650004
DW 01130140	ER40	1:1	6000	100	X	-	X	98.16	-	54	-	-	CHSTER40 OKU0650004
DW 01130240	ER40	1:1	6000	100	X	70	X	98.16	-	65	-	-	CHSTER40 OKU0650004
DW 01130325	ERA25	1:1	6000	100	X	-	X	65	-	54	-	CHUB27	CHTAER25ZC OKU0650004
DW 01130425	ERA25	1:1	6000	100	X	70	X	65	-	65	-	CHUB27	CHTAER25ZC OKU0650004
DW 01130516	Ø16x17	1:1	6000	100	X	-	X	-	67.5	54	16	17	CH_VTCROCE_M08 OKU0650004
DW 01130522	Ø22x19	1:1	6000	100	X	-	X	-	67.5	54	22	19	CH_VTCROCE_M10 OKU0650004
DW 01130527	Ø27x21	1:1	6000	100	X	-	X	-	70	54	27	21	CH_VTCROCE_M12 OKU0650004

SMEC (SAMSUNG)

MOD: SL 20/25/35 MC - PL 20/25/35 MC - SL2000T2Y2 - SL2500/3000 M/Y/SY - SL3500Y

MODULO MOTORIZZATO ASSIALE H=85mm

Axial driven tool H=85mm

Axial angetriebenes Werkzeug H=85mm

Subject to change without notice.

**M.T. srl**

Via Casino Albini 480  
Tel. 0541/956034-957884  
Fax 0541/956341

47842 S. GIOVANNI IN M. (RN)  
e-mail: mtma@mtmarchetti.com  
http://www.mtmarchetti.com



SMG150-1-15