

ATTENZIONE - ATTENTION - ACHTUNG

- Solo per mandrino principale
- Only for main spindle
- Nur für Hauptspindel

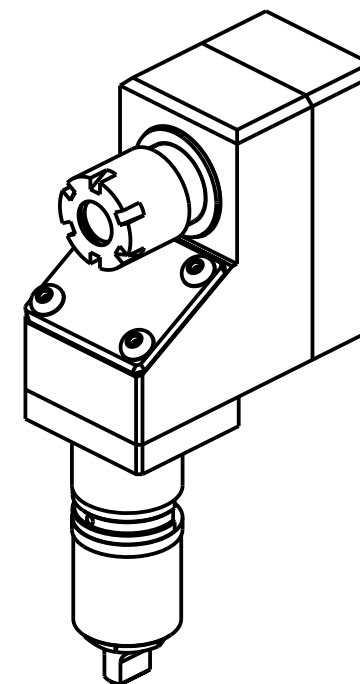
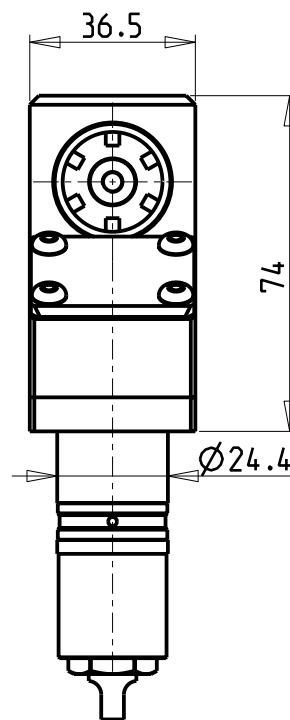
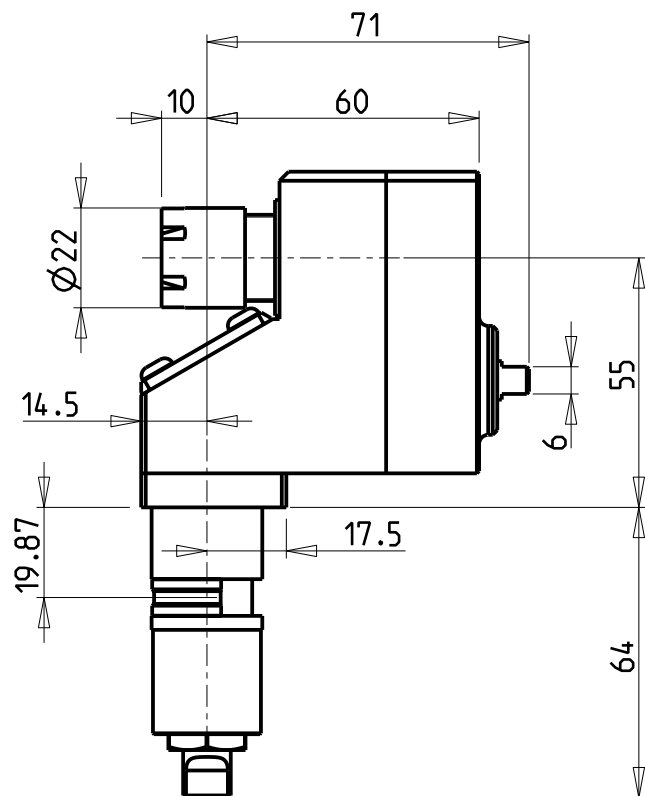

Cod. MT	Mandrino Spindel Spindel	I	RPM	Lubr.esterna Ext. coolant Aussenkuehlung	CHIAVI NON INCLUDE Keys not included Schluessel nicht einbegriffen
SPC0891000	ER16	1:1	6000	X	CHMNER16

DMG-MORI
 SPRINT 20/5 - SPRINT 20/8
 MODULO MOTORIZZATO ASSIALE ARRETRATO
 Axial rear-set driven tool
 Axial angetriebenes Werkzeug zurueckversetzt

Subject to change without notice.

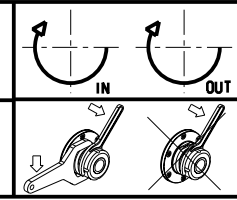

M.T. srl
 Via Casino Albini 480
 Tel. 0541/956034-957884
 Fax 0541/956341
 47842 S. GIOVANNI IN M. (RN)
 e-mail: mtma@mtmarchetti.com
 http://www.mtmarchetti.com



SPR180-1-20