

ATTENZIONE - ATTENTION - ACHTUNG

- Per lo smontaggio degli utensili utilizzare sempre la chiave di contrasto come indicato nel manuale d'uso.
- For disassembly of the tools use always the contrast key as mentioned in the user instructions.
- Fuer das Abmontieren der Werkzeuge immer den Gegenschlüssel benutzen wie in der Bedienungsanleitung erwaeht.

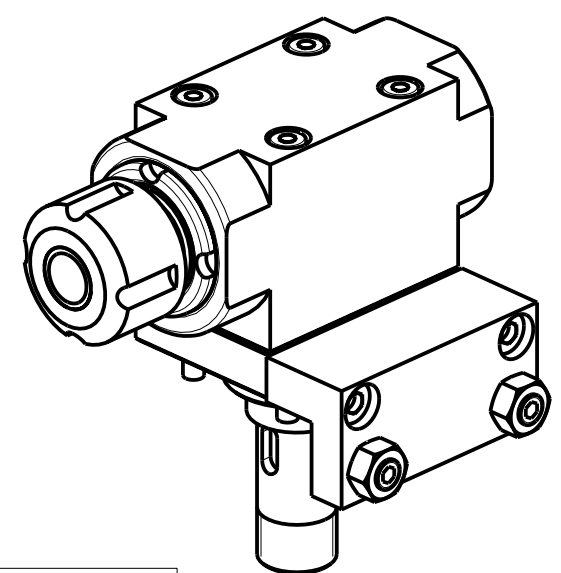

Cod. MT	Mandrino Spindel Spindel	I	RPM	Coppia Max Max Torque Max Drehmoment	Lubrificazione est. Ext. coolant Ausseinkuehlung	A	A1	D	L	Nota Note Note	CHIAVI NON INCLUSE Keys not included Schluessel nicht einbegriffen	
M0090416	ER16	1:1	6000	8Nm	X	60.9	-	-	-	-	CHUB08	CHSTER16
M0090112	$\varnothing 12$	1:1	6000	8Nm	X	-	42	12	13	PORTAFRESA A DISCO MILLING CUTTER HOLDER DISK FLASHALTER	CHUB08	CHUB19
M0090210	$\varnothing 10$	1:1	6000	8Nm	X	-	42	10	13		CHUB08	CHUB17
M0090308	$\varnothing 8$	1:1	6000	8Nm	X	-	42	8	13		CHUB08	CHUB13

TSUGAMI
MOD: BS20/26/32 CIII
MODULO MOTORIZZATO RADIALE
Radial driven tool
Radial angetriebenes Werkzeug

Subject to change without notice.

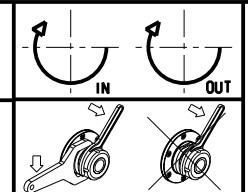

M.T. srl
 Via Casino Albini 480
 Tel. 0541/956034-957884
 Fax 0541/956341
 47842 S. GIOVANNI IN M. (RN)
 e-mail: mtma@mtmarchetti.com
 http://www.mtmarchetti.com



TSM010-1-00