

### ATTENZIONE - ATTENTION - ACHTUNG

- Per lo smontaggio degli utensili utilizzare sempre la chiave di contrasto come indicato nel manuale d'uso.
- For disassembly of the tools use always the contrast key as mentioned in the user instructions.
- Fuer das Abmontieren der Werkzeuge immer den Gegenschluessel benutzen wie in der Bedienungsanleitung erwaeht.

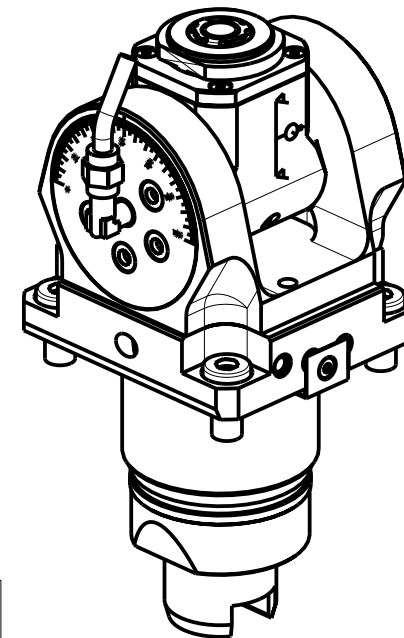

Cod. MT	Mandrino Spindle Spindel	I	RPM	Coppia Max Max Torque Max Drehmoment	Lubrificazione int. Coolant through Innenkuehlung	Lubrificazione est. Ext. coolant Aussenkuehlung	CHIAVI INCLUSE Keys included Schluessel inbegriffen			
TSM0100316	ERA16	1:2	10000	8Nm	-	X	CHUB19_SP3	CHUB32	CHTAER16ZC	CHESL07
TSM0100416	ERA16	1:2	10000	8Nm	P=70bar	X	CHUB19_SP3	CHUB32	CHTAER16ZC	CHESL07

TSUGAMI  
MOD: M06 - M08

MODULO MOTORIZZATO ORIENTABILE +/-90° MOLTIPLICATO I=1:2  
+/-90° adjustable angle driven tool geared-up I=1:2  
Angetriebenes Werkzeug schwenkbar +/-90° uebersetzt I=1:2

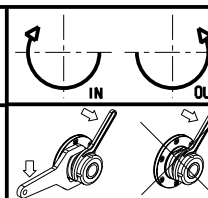

**M.T. srl**  
Via Casino Albini 480  
Tel. 0541/956034-957884  
Fax 0541/956341  
47842 S. GIOVANNI IN M. (RN)  
e-mail: mtma@mtmarchetti.com  
http://www.mtmarchetti.com



TSM336-3-00

Subject to change without notice.

03/2024