

## CUSCINETTI MAGGIORATI PER LAVORAZIONI PESANTI

Reinforced bearings for  
heavy machining

Vergroesserte Lager fuer  
schwerere Bearbeitungen

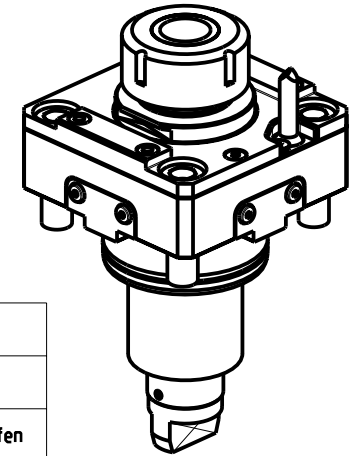
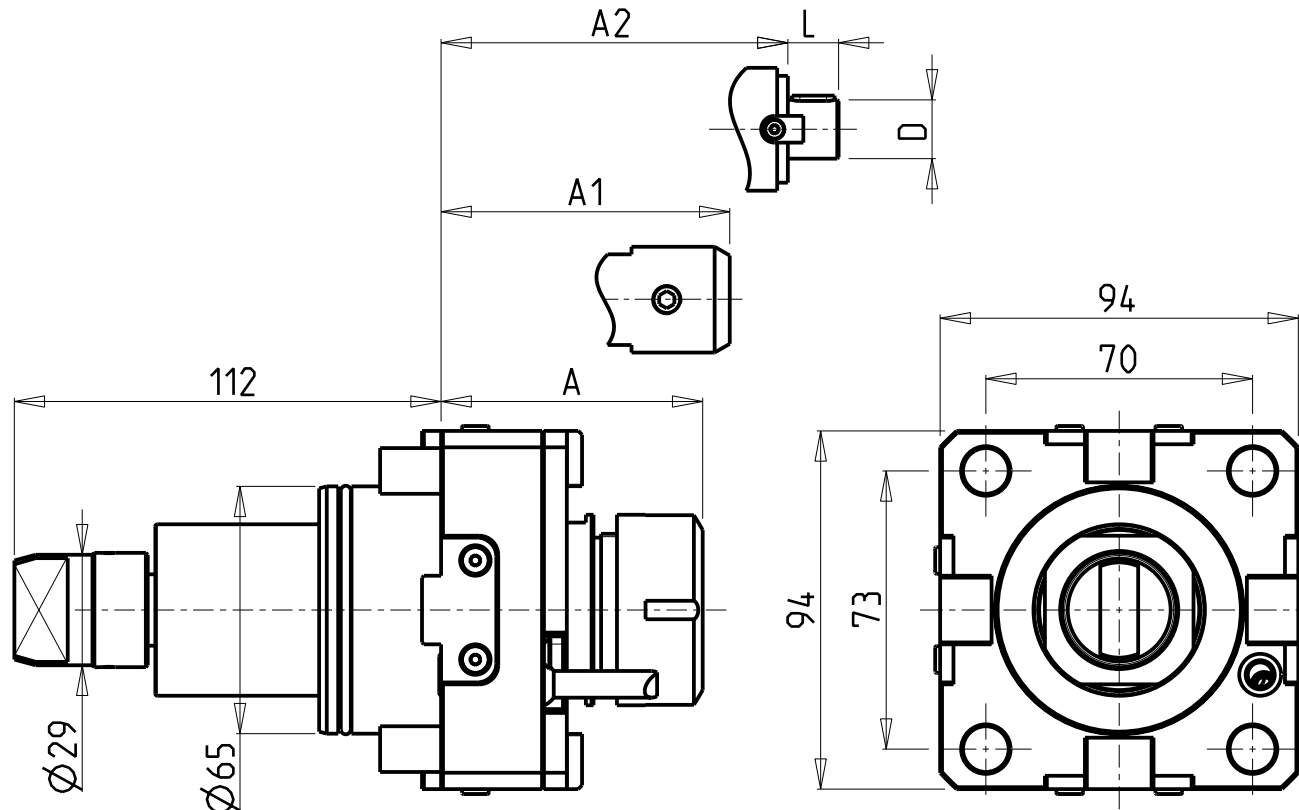

- Chiave inclusa
- Key included
- Schluessel inbegriffen

Cod. MT	Mandrino Spindle Spindel	I	RPM	Coppia Max Max Torque Max Drehmoment	Lubrificazione int. Coolant through Innenkuehlung	Lubrificazione est. Ext. coolant Aussenkuehlung	A	A1	A2	D	L	CHIAVI NON INCLUSE Keys not included Schluessel nicht einbegriffen	
DW 01540132	ER32	1:1	6000	100Nm	-	X	68.7	-	-	-	-	CHSTER32	OKU0650004
DW 03470232	ER32	1:1	6000	100Nm	P=70bar	X	79.2	-	-	-	-	CHSTER32	OKU0650004
DW 01540140	ER40	1:1	6000	100Nm	-	X	71.7	-	-	-	-	CHSTER40	OKU0650004
DW 03470240	ER40	1:1	6000	100Nm	P=70bar	X	82.2	-	-	-	-	CHSTER40	OKU0650004
DW 03470825	WELDON 25	1:1	6000	100Nm	P=70bar	X	-	72.5	-	-	-	-	OKU0650004
DW 01540827	Ø27x21	1:1	6000	100Nm	P=30bar	X	-	-	56.5	27	21	CH_VTCROCE_M12	OKU0650004

VICTOR

MOD: VTURN-A26 CM/SCM/YCM/YSCM - VTURN-S26 CM

MODULO MOTORIZZATO RADIALE MAGGIORATO

Radial reinforced driven tool

Radial angetriebenes Werkzeug vergroessert

Subject to change without notice.

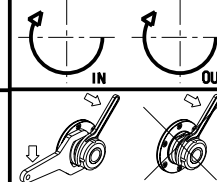

**M.T. srl**

Via Casino Albini 480  
Tel. 0541/956034-957884  
Fax 0541/956341  
47842 S. GIOVANNI IN M. (RN)  
e-mail: mtma@mtmarchetti.com  
http://www.mtmarchetti.com



VCT020-2-01