

ATTENZIONE - ATTENTION - ACHTUNG

- Per lo smontaggio degli utensili utilizzare sempre la chiave di contrasto come indicato nel manuale d'uso.
- For disassembly of the tools use always the contrast key as mentioned in the user instructions.
- Fuer das Abmontieren der Werkzeuge immer den Gegenschlüssel benutzen wie in der Bedienungsanleitung erwäehnt.

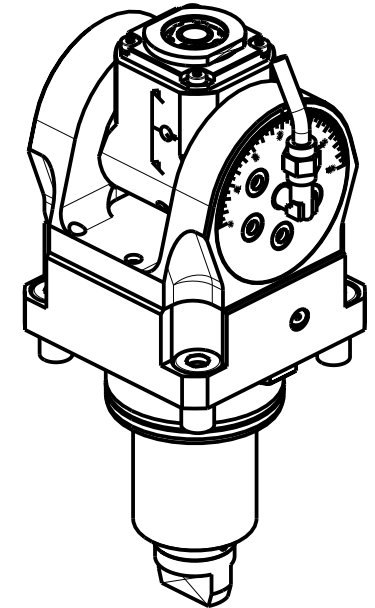

Cod. MT	Mandrino Spindle Spindel	i	RPM	Coppia Max Max Torque Max Drehmoment	Reversibile lato mandrino/contromandrino Reversible sub/main spindle side Umkehrbare Spindel-seite/ Gegenspindel-seite	Lubrificazione int. Coolant through Innenkuehlung	Lubrificazione est. Ext. coolant Aussenkuehlung	CHIAVI INCLUDE Keys included Schluessel inbegriffen			
					X	-	X	CHUB19_SP3	CHUB32	CHTAER16ZC	CHESL08
DW01940316	ERA16	1:2	12000	8Nm	X	-	X	CHUB19_SP3	CHUB32	CHTAER16ZC	CHESL08
DW01940416	ERA16	1:2	12000	8Nm	X	P=70bar	X	CHUB19_SP3	CHUB32	CHTAER16ZC	CHESL08

VICTOR
 MOD: VTURN-A26 CM/SCM/YCM/YSCM - VTURN-S26 CM

MODULO MOTORIZZATO ORIENTABILE ±90° MOLTIPLICATO i=1:2 H=72mm
 ±90° adjustable angle driven tool geared-up i=1:2 H=72mm
 Angetriebenes Werkzeug schwenkbar ±90° uebersetzt i=1:2 H=72mm

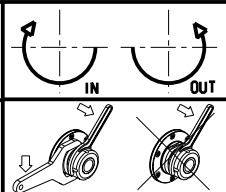

M.T. srl
 Via Casino Albini 480
 Tel. 0541/956034-957884
 Fax 0541/956341
 47842 S. GIOVANNI IN M. (RN)
 e-mail: mtma@mtmarchetti.com
 http://www.mtmarchetti.com



VCT336-2-00

Subject to change without notice.