

ATTENZIONE - ATTENTION - ACHTUNG

- VERIFICARE LE MISURE DI INGOMBRO PER POSSIBILE INTERFERENZA SU ALCUNI MODELLI DI MACCHINE
- Please check the overall sizes for possible interferences on some machine models
- Bitte überprüfen sie das ausmass um mögliche interferenzen auf einigen maschinen modellen zu vermeiden

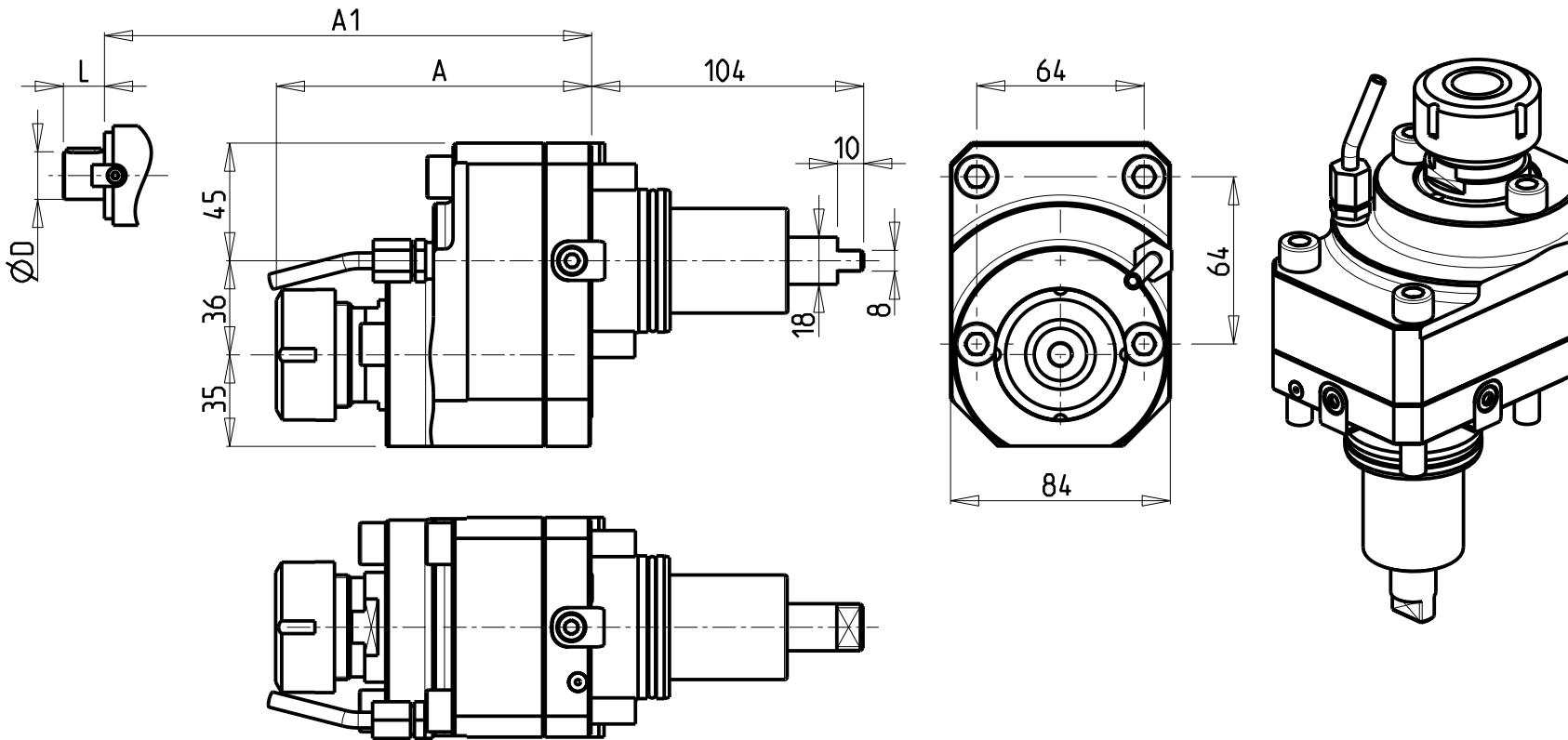

- Chiave inclusa
- Key included
- Schluessel inbegriffen

| Cod. MT | Mandrino Spindle Spindel | I | RPM | Coppia Max Max Torque Max Drehmoment | Reversibile lato mandrino/contromandrino Reversible sub/main spindle side Umkehrbare Spindel-seite/ Gegen-spindel-seite | Lubrificazione est. Ext. coolant Aussenkuehlung | A | A1 | D | L | CHIAVI NON INCLUSE Keys not included Schluessel nicht einbegriffen | |
|---------|--------------------------|-----|------|--------------------------------------|---|---|--------|------|----|----|--|------------|
| 0722132 | ER32 | 2:1 | 3000 | 65Nm | X | X | 120.56 | - | - | - | CHSTER32 | MNL0210007 |
| 0722116 | Ø16x17 | 2:1 | 3000 | 65Nm | X | X | - | 88.5 | 16 | 17 | CH_VTCROCE_M08 | MNL0210007 |
| 0722122 | Ø22x19 | 2:1 | 3000 | 65Nm | X | X | - | 90.5 | 22 | 19 | CH_VTCROCE_M10 | MNL0210007 |
| 0722127 | Ø27x21 | 2:1 | 3000 | 65Nm | X | X | - | 92.5 | 27 | 21 | CH_VTCROCE_M12 | MNL0210007 |

YCM
NT2000 16 STAZIONI - NTC1600/2000 M/LM/LS/Y/LY/LSY

MODULO MOTORIZZATO RADIALE RIDOTTO I=2:1 DISASSATO IN Z 36mm
Radial geared-down I=2:1 driven tool re-directed in Z by 36mm
Radial angetriebenes Werkzeug untersetzt I=2:1 achsversetzt in Z um 36mm

Subject to change without notice.

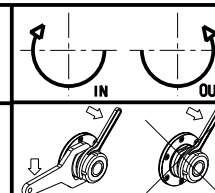

M.T. srl
Via Casino Albini 480
Tel. 0541/956034-957884
Fax 0541/956341
47842 S. GIOVANNI IN M. (RN)
e-mail: mtma@mtmarchetti.com
http://www.mtmarchetti.com



YCM030-1-20