

**ATTENZIONE - ATTENTION - ACHTUNG**

- VERIFICARE LE MISURE DI INGOMBRO PER POSSIBILE INTERFERENZA SU ALCUNI MODELLI DI MACCHINE
- Please check the overall sizes for possible interferences on some machine models
- Bitte überprüfen sie das ausmass um mögliche interferenzen auf einigen maschinen modellen zu vermeiden

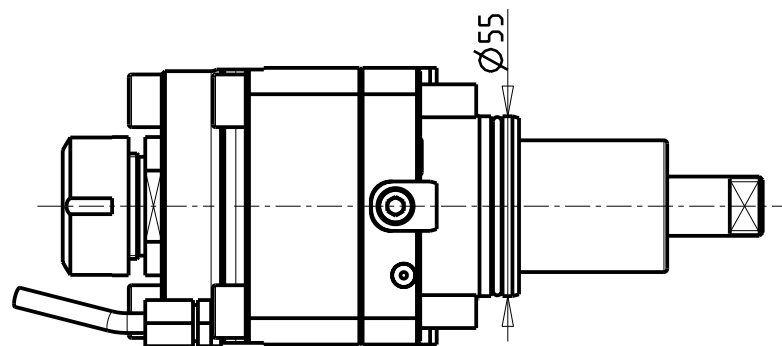
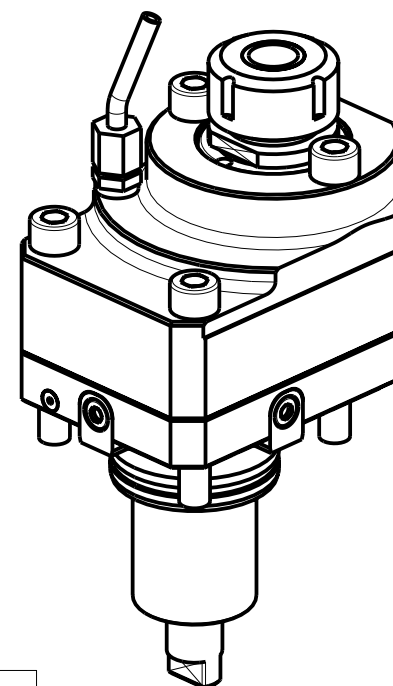

Cod. MT	Mandrino Spindle Spindel	I	RPM	Coppia Max Max Torque Max Drehmoment	Reversibile lato mandrino/contromandrino Reversible sub/main spindle side Umkehrbare Spindel-seite/ Gegenspindel-seite	Lubrificazione est. Ext. coolant Aussenkuehlung	A	CHIAVI NON INCLUSE Keys not included Schlüssel nicht einbegriffen	
0721225	ER25	1:2	12000	30Nm	X	X	108.56	CHSTER25	MNL0210007

YCM  
NT2000 16 STAZIONI - NTC1600/2000 M/LM/LS/Y/LY/LSY

MODULO MOTORIZZATO RADIALE MOLTIPLICATO I=1:2 DISASSATO IN Z 36mm  
Radial geared-up I=1:2 driven tool re-directed in Z by 36mm  
Radial angetriebenes Werkzeug uebersetzt I=1:2 achsversetzt in Z um 36mm

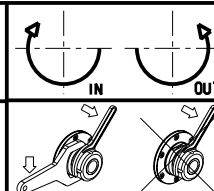

**M.T. srl**  
Via Casino Albini 480  
Tel. 0541/956034-957884  
Fax 0541/956341  
47842 S. GIOVANNI IN M. (RN)  
e-mail: mtma@mtmarchetti.com  
<http://www.mtmarchetti.com>



YCM030-1-30

Subject to change without notice.

03/2024