

**ATTENZIONE - ATTENTION - ACHTUNG**

- Per lo smontaggio degli utensili utilizzare sempre la chiave di contrasto come indicato nel manuale d'uso.
- For disassembly of the tools use always the contrast key as mentioned in the user instructions.
- Fuer das Abmontieren der Werkzeuge immer den Gegenschlüssel benutzen wie in der Bedienungsanleitung erwaeht.

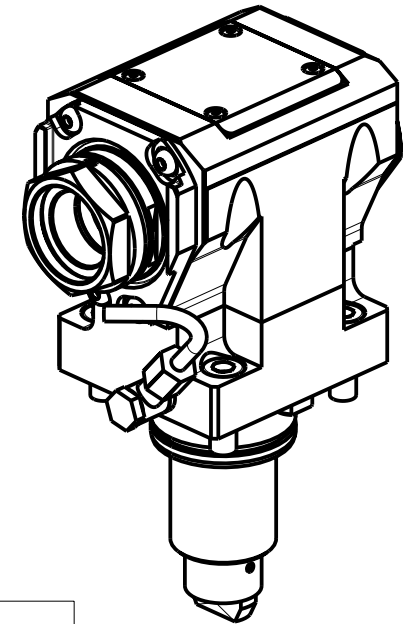
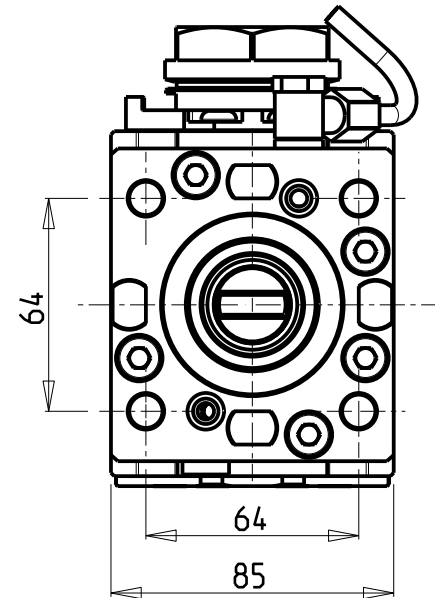
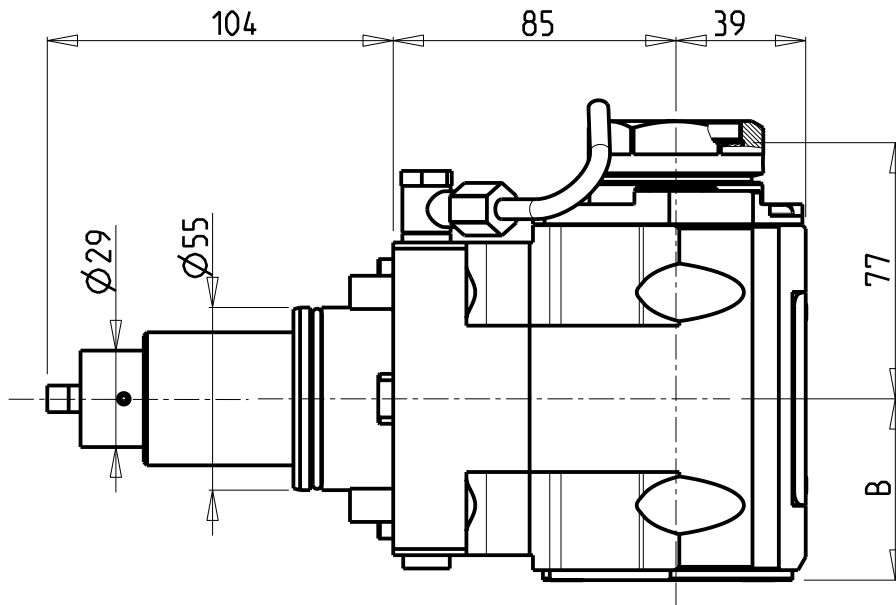

PER PORTAUTENSILI MODULARI MTSK-40 VEDI PAG. TBL300-1-40  
 FOR MTSK-40 QUICK CHANGE TOOLHOLDERS CLAMPINGS SEE PAGE TBL300-1-40  
 FUER MTSK-40 MODULARE WERKZEUGAUFNAHMEN SIEHE SEITE TBL300-1-40

Cod. MT	Mandrino Spindle Spindel	I	RPM	Coppia Max Max Torque Max Drehmoment	Reversibile lato mandrino/contromandrino Reversible sub/main spindle side Umkehrbare Spindel-seite/Gegenspindel-seite	Lubr.interna Coolant through Innenkuehlung	Lubr.esterna Ext. coolant Aussenkuehlung	B	CHIAVI NON INCLUDE Keys not included Schluessel nicht einbegriffen	
DW 00790140	MTSK-40	1:1	6000	70Nm	X	-	X	54.5	CHUB46	OKU0650004 •
DW 00790240	MTSK-40	1:1	6000	70Nm	X	P=70bar	X	65.5	CHUB46	OKU0650004 •

- Chiave inclusa
- Key included
- Schluessel inbegriffen

YCM  
 NT2000 16 STAZIONI - NTC1600/2000 M/LM/LS/Y/LY/LSY

MODULO MOTORIZZATO ASSIALE MTSK H=85mm  
 Axial MTSK driven tool H=85mm  
 Axial MTSK angetriebenes Werkzeug H=85mm

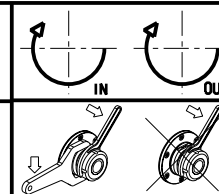

**M.T. srl**  
 Via Casino Albini 480  
 Tel. 0541/956034-957884  
 Fax 0541/956341  
 47842 S. GIOVANNI IN M. (RN)  
 e-mail: mtma@mtmarchetti.com  
 http://www.mtmarchetti.com



YCM150-1-31-K

Subject to change without notice.