

ATTENZIONE - ATTENTION - ACHTUNG

- VERIFICARE LE MISURE DI INGOMBRO PER POSSIBILE INTERFERENZA SU ALCUNI MODELLI DI MACCHINE
- Please check the overall sizes for possible interferences on some machine models
- Bitte überprüfen sie das ausmass um mögliche interenzen auf einigen maschinen modellen zu vermeiden

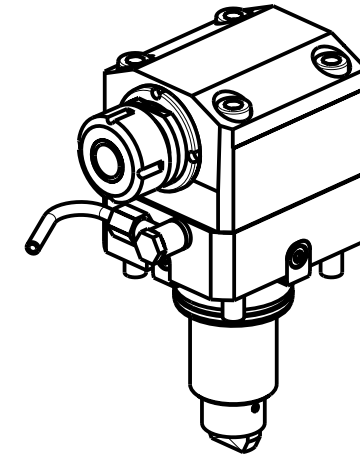
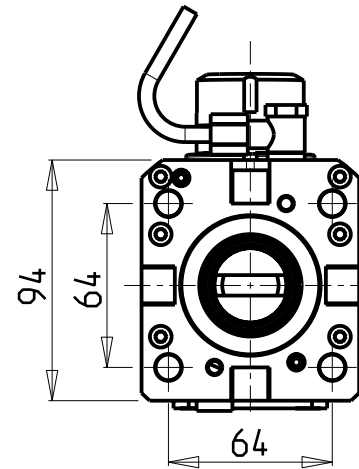
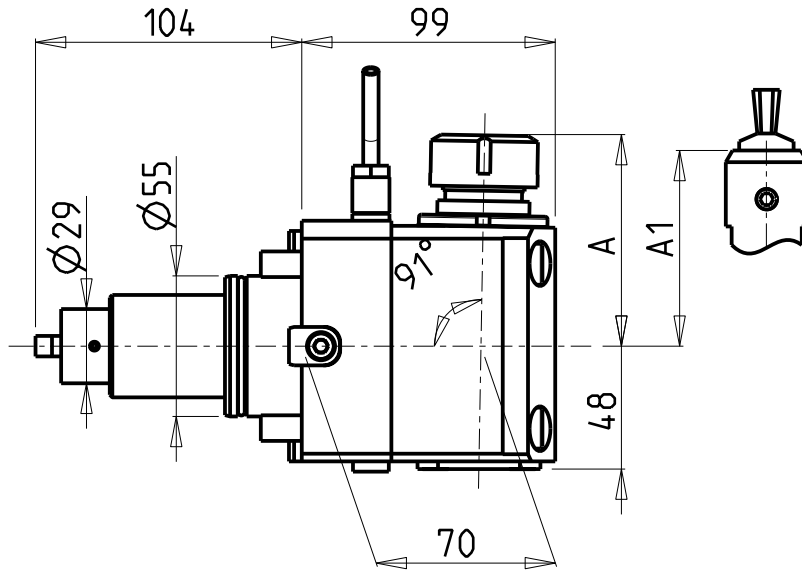

Cod. MT	Mandrino Spindle Spindel	I	RPM	Coppia Max Max Torque Max Drehmoment	Reversibile lato mandrino/contromandrino Reversible sub/main spindle side Umkehrbare Spindel-seite/Gegenspindel-seite	Lubrificazione est. Ext. coolant Ausenkuehlung	A	A1	CHIAVI NON INCLUSE Keys not included Schlüssel nicht einbegriffen	
DW00249125	ER25	1:1	6000	50Nm	X	X	82.35	-	CHSTER25	CHUB36 o 0100000
DW00249108	WELDON 8	1:1	6000	50Nm	X	X	-	76.5		
DW00249110	WELDON 10	1:1	6000	50Nm	X	X	-	76.5		
DW00249112	WELDON 12	1:1	6000	50Nm	X	X	-	76.5		
DW00249116	WELDON 16	1:1	6000	50Nm	X	X	-	76.5		

YCM
NT2000 16 STAZIONI - NTC1600/2000 M/LM/LS/Y/LY/LSY

MODULO MOTORIZZATO ASSIALE PER POLIGONATURA INTERNA H=70mm
Axial driven tool for internal polygon-making H=70mm
Axial angetriebenes Werkzeug fuer interne Facettierung H=70mm

Subject to change without notice.

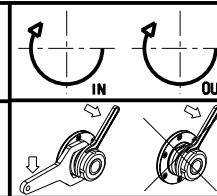

M.T. srl
Via Casino Albini 480
Tel. 0541/956034-957884
Fax 0541/956341
47842 S. GIOVANNI IN M. (RN)
e-mail: mtma@mtmarchetti.com
http://www.mtmarchetti.com

