

ATTENZIONE - ATTENTION - ACHTUNG

- Per lo smontaggio degli utensili utilizzare sempre la chiave di contrasto come indicato nel manuale d'uso.
- For disassembly of the tools use always the contrast key as mentioned in the user instructions.
- Fuer das Abmontieren der Werkzeuge immer den Gegenschlüssel benutzen wie in der Bedienungsanleitung erwahnt.

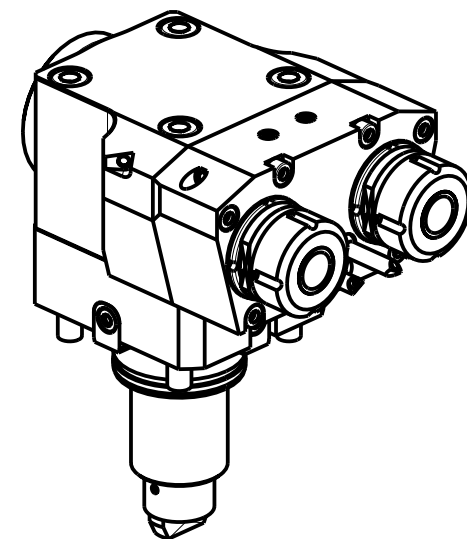

Cod. MT	Mandrino Spindle Spindel	I	RPM	Coppia Max Max Torque Max Drehmoment	Reversibile lato mandrino/contromandrino Reversible sub/main spindle side Umkehrbare Spindelsete/ Gegenspindelsete	Lubrificazione est. Ext. coolant Aussenkuehlung	A	CHIAVI NON INCLUSE Keys not included Schluessel nicht einbegriffen	
								CHMNER16	CHUB17
DW 00951216	ER16	1:2	12000	20Nm	X	X	115	CHMNER16	CHUB17
DW 00951225	ER25	1:2	12000	20Nm	X	X	115.96	CHSTER25	CHUB36

YCM
NT2000 16 STAZIONI - NTC1600/2000 Y/LY/LSY

MODULO MOTORIZZATO ASSIALE 2 USCITE IN Y MOLTIPLICATO I=1:2 H=70mm
Axial geared-up I=1:2 single side twin head driven tool in Y H=70mm
Axial angetriebenes Werkzeug 2 Ausgaenge in Y uebersetzt I=1:2 H=70mm

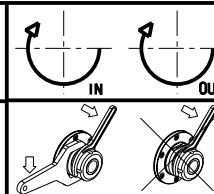

M.T. srl
Via Casino Albini 480
Tel. 0541/956034-957884
Fax 0541/956341
47842 S. GIOVANNI IN M. (RN)
e-mail: mtma@mtmarchetti.com
http://www.mtmarchetti.com



YCM261-1-20

Subject to change without notice.

03/2024